

# Evaluation of Thin Polymer Overlays for Bridge Decks

---

Habib Tabatabai  
Konstantin Sobolev  
Al Ghorbanpoor  
Azam Nabizadeh  
Chin-Wei Lee  
Matthias Lind

University of Wisconsin-Milwaukee

WisDOT ID no. 0092-12-06

July 2016



RESEARCH & LIBRARY UNIT



WISCONSIN HIGHWAY RESEARCH PROGRAM

**WISCONSIN DOT**  
PUTTING RESEARCH TO WORK

## **DISCLAIMER**

This research was funded through the Wisconsin Highway Research Program by the Wisconsin Department of Transportation and the Federal Highway Administration under Project # 0092-12-06. The contents of this report reflect the views of the authors who are responsible for the facts and the accuracy of the data presented herein. The contents do not necessarily reflect the official views of the Wisconsin Department of Transportation or the Federal Highway Administration at the time of publication.

This document is disseminated under the sponsorship of the Department of Transportation in the interest of information exchange. The United States Government assumes no liability for its contents or use thereof. This report does not constitute a standard, specification, or regulation.

The United States Government does not endorse products or manufacturers. Trade and manufacturers' names appear in this report only because they are considered essential to the object of the document.

## TECHNICAL REPORT DOCUMENTATION PAGE

1. Report No. 0092-12-06	2. Government Accession No	3. Recipient's Catalog No	
4. Title and Subtitle Evaluation of Thin Polymer Overlays for Bridge Decks		5. Report Date July 2016	
		6. Performing Organization Code	
7. Authors Habib Tabatabai, Konstantin Sobolev, Al Ghorbanpoor, Azam Nabizadeh, Chin-Wei Lee, and Matthias Lind		8. Performing Organization Report No.	
9. Performing Organization Name and Address Department of Civil and Environmental Engineering University of Wisconsin-Milwaukee 3200 North Cramer Street, Milwaukee, WI 53211		10. Work Unit No. (TRAIS)	
		11. Contract or Grant No. 0092-12-06	
12. Sponsoring Agency Name and Address Wisconsin Department of Transportation Research & Library Unit 4802 Sheboygan Avenue, Rm 104 Madison, WI 53707		13. Type of Report and Period Covered	
		14. Sponsoring Agency Code	
15. Supplementary Notes			
<b>16. Abstract</b> Deterioration of concrete bridge decks is a major maintenance concern particularly in the northern snow-belt regions where deicing salt is used to maintain traffic during winter months. Overlays and sealers have long been utilized in protection and repair strategies for bridge decks. Polymer overlays are used on decks to reduce the penetration of chloride ions (and the resulting corrosion) and to improve skid resistance (increase friction). Because of their small thicknesses (generally 0.25 to 0.75 in), polymer overlays impose less additional dead weight and can be applied more rapidly compared to other types of overlay. The objectives of this research project were to explore the effectiveness and durability of thin polymer overlays with respect to restoring and protecting bridge decks, improving safety, and extending service life; to assess and compare performance of selected thin polymer overlay systems under laboratory test conditions; and to suggest appropriate bridge deck maintenance strategies related to this research. An experimental research program was performed to study and compare the performance of nine different overlay systems. Reinforced concrete slab specimens were subjected to accelerated corrosion, freeze-thaw cycling, heat/ultraviolet/rain cycles, and tire wear tests (including "snow plow" application). The overlay system with an epoxy resin and flint rock aggregate provided the best overall performance based on performance indices determined for friction coefficient, corrosion mass loss, pull-out strength and surface deformation (rut) due to tire passage. The polyester multi-lift overlay system delaminated from the concrete surface in all nine specimens utilizing that overlay type. The addition of polymer overlays does not significantly reduce corrosion mass loss in bridge decks with high levels of chloride contamination. Recommended guidelines for maintenance of bridge decks are provided.			
17. Key Words Bridge decks, corrosion, friction, overlays, thin polymer overlay, durability		18. Distribution Statement No restriction. This document is available to the public through the National Technical Information Service 5285 Port Royal Road Springfield VA 22161	
19. Security Classif. (of this report) Unclassified	19. Security Classif. (of this page) Unclassified	20. No. of Pages 100	21. Price

## Table of Contents

ACKNOWLEDGEMENTS .....	6
DISCLAIMER .....	7
TECHNICAL REPORT DOCUMENTATION PAGE .....	8
EXECUTIVE SUMMARY .....	9
1.0 INTRODUCTION .....	12
1.1 Background .....	12
Overlays .....	12
Sealers .....	14
1.2 Objectives and Scope .....	15
2.0 LITERATURE REVIEW .....	16
3.0 SURVEY RESULTS .....	19
3.1 Previous Surveys (by Others) .....	19
3.2 State Survey Results – This Study .....	26
3.3 Supplier Survey Results – This Study .....	28
3.4 Summary of Survey Results .....	30
4.MATERIAL SELECTION AND EXPERIMENTAL DESIGN .....	31
4.1 Material Selection .....	31
4.2 Laboratory Testing Procedures .....	32
4.2.1 Test Specimens .....	32
4.2.2 Introduction of Initial Chlorides .....	38
4.2.3 Overlay Applications .....	39
4.2.4 Exposure Rounds .....	40
4.2.5 Tests and Measurements .....	56
4.3 Field Testing .....	63
5.0 EXPERIMENTAL RESULTS.....	69
5.1 Pull-Out Test Results .....	69
5.1.1 Initial (baseline or Round 0) Pull-Out Strength.....	69
5.1.2 Final Pull-Out Strength .....	70
5.1.3 Discussion of Pull-Out Results .....	73
5.2 Friction Test Results .....	73
5.2.1 Initial Friction Results.....	73
5.2.2 Final Friction Results.....	74
5.2.3 Discussion of Friction Results .....	77
5.3 Corrosion Test Results .....	78

5.3.1 Final Corrosion Results.....	78
5.3.3 Discussion of Corrosion Results.....	81
5.4 Surface Profile Results.....	81
5.4.1 Final Surface Profile Results .....	81
5.4.2 Discussion of Surface Profile Results.....	83
5.5 Overall Analysis of Laboratory Results.....	84
5.5.1 Indexed Final Results.....	84
5.5.3 Observations on the Laboratory Test Results .....	89
5.6 Field Tests – Initial Friction Results.....	91
5.6.1 Initial BPT results .....	91
5.6.2 Failure of an Overlay System .....	91
6.0 CONCLUSIONS AND RECOMMENDATIONS .....	92
6.1 Summary and Conclusions .....	92
6.2 Recommended Guidelines .....	95
7.0 REFERENCES .....	98

## List of Figures

Figure 1. Concrete test specimen (with and without overlay).	36
Figure 2. Concrete specimen preparation.	37
Figure 3. Group B and C specimens undergoing initial chloride/accelerated corrosion exposure.	39
Figure 4. Placement of thin polymer overlay on test specimen.	40
Figure 5. Multi-lift overlay placements.	41
Figure 6. Pre-mixed polyester overlay system (S7) placement.	41
Figure 7. Test exposure cycles.	42
Figure 8. Accelerated corrosion setup.	44
Figure 9. Accelerated corrosion exposure setup.	45
Figure 10. Automated computer-controlled machine for FT, HURA and wear testing of specimens.	46
Figure 11. One of the three carts used for manual FT testing.	47
Figure 12. FT drawer with specimen placed face-down.	48
Figure 13. HURA test cycles: Heat and UV (left), rain and cool down (right).	49
Figure 14. Manual HURA test box.	50
Figure 15. Three-Wheel Polishing Device (TWPD) developed by National Center for Asphalt Technology (NCAT) (Erukulla, 2011).	53
Figure 16. UWM-designed wear test device (conceptual drawing).	53
Figure 17. UWM-designed wear test device.	54
Figure 18. Dimension of the “snow plow” using in Round 3 wear test.	55
Figure 19. “Snow plow” assembly installed between two tires.	56
Figure 20. British Pendulum Tester used on specimens prior to exposure tests.	57
Figure 21. Friction measuring system for the UWM wear test machine.	58
Figure 22. Typical friction sensor output.	58
Figure 23. Coring drill setup.	60
Figure 24. Schematic layout of sample coring locations after the end of exposure tests.	60
Figure 25. Pull-out test device.	61
Figure 26. Measurement of the depth of surface groove (rut) through a dial gage at measurement points defined using a wooden template.	62
Figure 27. Marquette Interchange ramp prior to application of overlays (transverse cracking of the deck is observed).	64
Figure 28. Cross section of Marquette Interchange ramp (from WisDOT project drawing).	65
Figure 29. Friction testing using BPT.	65
Figure 30. Placement of resin and aggregate on a 2-lift overlay system.	66
Figure 31. Marquette Interchange ramp after placement of four different thin polymer overlay systems (A through D).	66
Figure 32. Four different thin polymer overlay test sections (A, B, C, and D) on the Marquette Interchange ramp (from WisDOT).	66
Figure 33. Section A drawing (from WisDOT).	67
Figure 34. Section B drawing (from WisDOT).	67
Figure 35. Section C drawing (from WisDOT).	68
Figure 36. Section D drawing (from WisDOT).	68
Figure 37. Average initial pull-out strength (baseline).	70
Figure 38. Average final pull-out strength of all groups.	72
Figure 39. Pictures of delaminated overlay from a S8 specimen: top surface (left), bottom surface (right).	72
Figure 40. Average final pull-out strength for groups A, B, and C.	73
Figure 41. Initial average coefficients of friction for all groups at Round 0.	74

Figure 42. Average coefficient of friction for all groups at round 3.....	75
Figure 43. Coefficient of friction for groups A, B, and Cat Round 3. ....	76
Figure 44. Average coefficient of friction for all groups at round 0, 1, 2, and 3.....	77
Figure 45. Projected coefficients of friction for various overlay types. ....	79
Figure 46. Average corrosion mass loss for all groups.....	80
Figure 47. Average corrosion mass loss for Groups A, B, and C.....	81
Figure 48. Surface profile average for all groups of overlay types. ....	83
Figure 49. Average surface profile for groups A, B, and C.....	83
Figure 50. Overlay Performance Index (I <sub>4</sub> ) - Combined pull-out strength, friction, corrosion, and surface profile indices.....	87
Figure 51. Overlay Performance Index (I <sub>3</sub> ) - Including pull-out strength, friction, and corrosion indices. ....	88
Figure 52. Overlay Performance Index (I <sub>2</sub> ) - Including pull-out strength, and friction indices. ....	89
Figure 53. Delaminated multi-lift polyester overlay (from the Marquette Interchange ramp).....	91

## List of Tables

Table 1. Summary of Survey Results from NCHRP Synthesis Report 423 (Fowler and Whitney, 2011). .....	22
Table 2. Reasons for selection of Polymer overlays (Krauss et al., 2009). .....	24
Table 3. Deck conditions that can be addressed by polymer overlays (Krauss et al, 2009). .....	25
Table 4. Surface preparation techniques in polymer overlays (Krauss et al, 2009). .....	26
Table 5. Surface evaluation prior to installing polymer overlays (Krauss et al, 2009). .....	26
Table 6. Commercially available products for thin polymer overlays.....	33
Table 7. Selected Test Products/Methods. ....	34
Table 8. Product information provided by suppliers for various polymer overlay products. ....	35
Table 9. Grouping of test specimens.....	37
Table 10. Description of polymer overlay types used on Marquette Interchange ramp. ....	64
Table 11. Initial (baseline) results of pull-out tests.....	69
Table 12. Final average pull-out strength for all groups.....	71
Table 13. Final average pull-out strength for groups A, B, and, C.....	71
Table 14. Initial (Round 0) average coefficient of friction of all groups.....	74
Table 15. Final coefficient of friction (Round 3) values for groups A, B, and C.....	75
Table 16. Average coefficient of friction for all groups at round 0, 1, 2, and 3. ....	76
Table 17. Parameters for Modified Exponential Fit-Curve. ....	78
Table 18. Average corrosion mass losses and standard deviations for Groups A, B, and C. ....	79
Table 19. Average corrosion mass losses and standard deviations for all specimen groups.....	80
Table 20. Average surface deformations for groups A, B, and C.....	82
Table 21. Average surface deformations of all groups. ....	82
Table 22. Index values for pull-out strength.....	85
Table 23. Index values for coefficient of friction results.....	85
Table 24. Index values for corrosion mass loss. ....	86
Table 25. Index values for surface profile results.....	86
Table 26. Combined performance index $I_4$ – Combined pull-out strength, friction, .....	87
Table 27. Combined performance index $I_3$ – Combined pull-out strength, friction, .....	88
Table 28. Combined performance index $I_2$ – Combined pull-out strength, and friction. ....	89
Table 29. Summary of best (highest) and worst (lowest) performance Indices. ....	90
Table 30. Summary of best and worst indices in graphical form. ....	90
Table 31. Average Friction Test Results Using British Pendulum Tester.....	91
Table 32. Summary of Experimental Results .....	93



## **ACKNOWLEDGEMENTS**

The project team appreciates the support of the Wisconsin Highway Research Program (WHRP) in sponsoring this research project. We especially thank Mr. William Oliva, Mr. Travis McDaniel, and Mr. David Bohnsack of the Wisconsin Department of Transportation and other members of the project oversight committee for their help and input.

Funding for the tests on one of the nine overlay systems discussed in this report was provided by Dow Poly Carb, Inc.

Special thanks are due to the many staff members and students at the University of Wisconsin-Milwaukee who helped with this project including Rahim Reshadi, Brian Mullen, Ali Ehsan Ali, Kenneth Sosinski, Jorge Henrique Lima Reis, Marinara Andrade Do Nascimento, Sam Rusch, and Tye Rodriguez.

## EXECUTIVE SUMMARY

Deterioration of concrete bridge decks is a major maintenance concern particularly in the northern snow-belt regions where deicing salt is used to maintain traffic during winter months. Overlays and sealers have long been utilized in protection and repair strategies for bridge decks. Polymer overlays are used on decks to reduce the penetration of chloride ions (and the resulting corrosion) and to improve skid resistance (increase friction). Because of their small thicknesses (generally 0.25 to 0.75 in), polymer overlays impose less additional dead weight and can be applied more rapidly compared to other types of overlay.

States may utilize differing criteria when deciding whether to use overlays. These criteria may include chloride content at the level of reinforcing bars, percent delamination of the deck, and the depth of cover over reinforcement. For example, a study in Virginia (Sprinkel et al., 1993) recommended that all concrete with chloride contents over 1.0 lb./yd<sup>3</sup> be removed prior to placement of overlay. The rationale for such a recommendation is that the corrosion activity may continue unabated when significant chloride contamination exists under the overlay.

The objectives of this research project were to explore the effectiveness and durability of thin polymer overlays with respect to restoring and protecting bridge decks, improving safety, and extending service life; to assess and compare performance of selected thin polymer overlay systems under laboratory test conditions; and to suggest appropriate bridge deck maintenance strategies related to this research.

An experimental research program was designed and conducted to study and compare the performance of nine different overlay systems (designated S1 through S9) against each other and against a set of uncoated control specimens (designated S0). A total of 84 reinforced concrete slab specimens were subjected to accelerated corrosion (saltwater exposure and imposition of an electrical potential to the reinforcing bars), freeze-thaw cycles, heat/ultraviolet/rain exposure cycles, and tire wear tests (including simulated “snow plow” passages). Application of overlays on previously chloride-contaminated concrete was also studied through exposure of two sets of specimens to increasing chloride (corrosion) levels prior to application of overlays. A number of parameters including pull-out strength (bond between overlay and concrete surface), friction, deformation due to tire passages (rutting), and corrosion mass loss were measured. The specimens were dissected at the conclusion of testing for further examination and measurement of corrosion mass loss on the top reinforcing bars. The results of the testing program are discussed in detail in this report. The main results can be summarized as follows:

- One of the nine overlay systems tested (S8 - a 2-lift polyester multi-lift overlay) exhibited complete delamination from the concrete surface during testing even though its initial pull-out strength was in line with the other eight overlay types. This overlay system had the worst overall performance based on numerical indices given to various performance parameters, or combinations of those parameters. In general, aside from the poor performance of S8, there were variations in performance of all other TPO systems tested (as discussed below); however, such differences were not drastic.
- Friction test results prior to environmental exposures indicated that the tined concrete surface (concrete surface without overlay - control) had the highest initial friction values. However, the control specimen (without overlay) had the lowest friction values at the end of all testing. This indicates that the polymer overlay systems help retain surface friction values.
- The overlay system utilizing epoxy resin with flint rock provided the highest friction, and the best overall performance indices, at the end of testing.
- Of the three aggregate types (flint, granite, and calcined bauxite) used with the same epoxy resin (S1, S2, S3), the flint rock resulted in the highest friction values at the end of tests, while calcined bauxite exhibited the lowest friction results. The only overlay system with the taconite aggregate (S9) provided the second highest friction values at the end of testing.
- The epoxy-based overlays (with different aggregate types) and the polyester premix system offered reduced corrosion losses when compared to the control specimens. However, the addition of overlays does not significantly reduce corrosion mass loss when specimens are already contaminated with chlorides prior to installation of overlays.
- As far as pull-out strength (at the end of testing) is concerned, the epoxy overlay systems with calcined bauxite and flint aggregates (S3 and S1) provided the highest and second highest strengths, respectively. The lowest and the second lowest pull-out strengths were observed in the polyester multi-lift system (S8) and the overlay system with taconite (S9), respectively.
- The main advantage of thin polymer overlays is the long-term preservation of friction coefficients as the deck ages relative to the concrete without overlay. Therefore, for applications where friction enhancements are needed, the thin polymer overlays are recommended unless chloride contamination, corrosion, and/or deck surface conditions preclude its use.

- Proper installation of the overlays is crucial. Special effort and proper quality controls are needed to ensure that the overlay is installed properly. If the installation is done correctly, most of the tested systems (with the exception of the system described above) can perform without premature delamination.
- During freeze-thaw testing, it was observed that some aggregates would become loose and leave the overlay system after each round of freeze-thaw cycles. It is anticipated that the loss of aggregates would continue with time. Since aggregates provide a physical barrier protecting the polymer against deterioration due to ultraviolet radiation from the sun, it is expected that a longer-term mode of damage may be related to UV degradation of the polymer following loss of aggregates.
- Based on information in the literature, survey findings, and results from this study, it is anticipated that the service life of a 2-lift thin polymer overlay would be on the order of 7 to 15 years, if early premature failures do not occur. A service life of 10 years can be assumed for economic analyses.
- If the purpose for the installation of the thin polymer overlay is to protect an uncontaminated deck against corrosion, a more cost effective approach may be to apply penetrating sealer instead shortly after construction, and repeating the sealer application periodically thereafter. However, on heavily-travelled roads, routine reapplication of sealers can be particularly disruptive to traffic. In such cases, thin polymer overlays can be applied as a corrosion protection measure, especially if the overlay is applied early in the bridge deck's life before substantial chloride contamination has occurred.
- The addition of polymer overlays does not significantly reduce corrosion mass loss in bridge decks with high levels of prior chloride contamination. Therefore, the placement of a thin polymer overlay on a chloride contaminated bridge deck undergoing active corrosion of the embedded steel cannot be considered to be an effective corrosion mitigation strategy. Such a step (application of thin polymer overlay) may still be taken in these situations for other reasons such as improving friction or providing a smooth riding surface over a limited time period. However, the overlay must be installed on sound concrete under all circumstances, and it must be realized that the overlay may eventually fail due to effect of corrosion of the underlying reinforcement, if not for other factors.
- A set of guidelines for the maintenance of bridge decks is provided in Chapter 6.

# 1.0 INTRODUCTION

## *1.1 Background*

Concrete bridges in Wisconsin and elsewhere have shown varying signs of deterioration due to aging and other detrimental factors. Considering the enormous cost and effort required to remedy bridge deficiencies, it is crucial that a concerted effort be made to develop and implement practical, effective and economical methods and guidelines for protection, repair and rehabilitation of bridges.

Deterioration of concrete bridge decks is a major maintenance problem particularly in the northern snow-belt regions where deicing salt is used to maintain traffic during the winter months. Bridge decks are a significant deterioration concern as they are directly subjected to vehicular effects (load, abrasion,...), deicing salts and freeze-thaw cycles. Chloride ions can penetrate into the concrete and reach the level of reinforcing steel in concrete. This results in the loss of alkaline environment in concrete and the elimination of the surface passivity of steel reinforcement. The outcome is initiation of corrosion of steel in concrete. The problem is further amplified due to the expansive nature of the corrosion products.

To address these problems, overlays and sealers have long been utilized in protection and repair strategies for bridge decks. In the following, a brief discussion of overlays and sealers is presented.

### Overlays

In general, deck overlays include asphalt concretes with or without membranes, latex or micro-silica modified concrete, high-early-strength hydraulic cement concretes, and polymer overlays. Polymer overlays are used on decks to reduce penetration of chloride ions, and to increase skid resistance (friction). Because of their small thicknesses (generally 0.25 to 0.75 in), polymer overlays impose less additional dead weight compared to other types of overlay. Such overlays can also be applied rapidly with lane closures of 8 hours or less.

States utilize differing criteria when deciding whether to use overlays. These criteria include chloride content, percent delamination of the deck, and the depth of cover over reinforcement. For example, the Washington State DOT criteria recommends use of overlays if a) the chloride level at the level of reinforcement exceeds 2 lb/yd<sup>3</sup>; or 2) delamination (using chain drag) exceeds 2% of deck area; or c) over 15% of measurements show a reinforcement cover of less than 1 inch (Wilson and Henley, 1995). However, others may not agree with the above conditions. Sprinkel et al (1993) recommended that all concrete with chloride contents over 1.0 lb/yd<sup>3</sup>, or half-cell potentials of -0.250 V (CSE) or less, be

removed prior to placement of overlay. The rationale is that corrosion activity will continue unabated when significant chloride contamination exists under the overlay.

Sprinkel et al (1995) categorize polymer overlays into three basic types: multi-layer, pre-mixed and slurry. Multi-layer polymer overlays (generally two layers) are the most common type of thin polymer overlays used. In this method, patch repairs of delaminated deck areas are first performed as needed. Then, the deck surface is shot-blasted and cleaned. The most common resin used in this approach is epoxy. However, methyl methacrylate (MM), epoxy-urethanes, polyesters, and other resins are also used. A primer may (or may not) be first applied. The resin is then mixed with hardener and applied by sprayer, brush, roller, or squeegee onto the surface. Resin thickness would be on the order of 30 to 40 mils. Typically, a gap-graded clean aggregate is then broadcast on the resin. There is consensus that the type and quality of aggregates are crucial in the effectiveness of thin polymer overlays. Basalt-type aggregates are commonly specified. A short time after the resin application (when the resin is cured), the excess aggregates are broomed or vacuumed and another layer of resin and aggregates is applied (for a two-layer system).

A proprietary thin polymer overlay system was designed to help reduce icing and accidents by using aggregates that absorb and re-release deicing agents when needed later (Evans 2010, Sprinkel et al, 2009). However, its performance was not considered adequate in some early installations.

For premixed overlays, the binder (usually polyester styrene), aggregates, and initiator are mixed, placed on the deck and finished with a vibrating screed. The thickness of premixed overlay is typically between 0.5 and 1.0 in. Slurry overlays include mixing a flowable polymer mortar on a primed deck surface (0.25 in thick) followed by broadcasting aggregates on the slurry. Excess aggregates are removed and a seal coat is sometimes applied. The total thickness of this system is about 0.38 in, and the most common binders are epoxy and methacrylate.

Nelson (2005) identified the following factors as contributing to failure in polymer overlays: improper binder selection; inadequate surface preparation; improper aggregate selection; improper mixing-application-curing; and damage due to ultraviolet radiation. The coefficient of thermal expansion of the overlay system should be compatible with that of the deck concrete. A flexible and solvent-free binder helps avoid delamination (Appendix A of ACI 503, 1993). A good polymer overlay should have bond strength of better than 250 psi (Nelsen, 2005). According to Nelsen, the resin material should have a tensile strength and elongation capability of at least 2000 psi and 30%, respectively. Nelsen also recommended that polymer overlays not be applied on concretes with rebar level chloride contents of 1.5 lb./yd<sup>3</sup> or higher. Excessive moisture in the concrete at the time of application can lead to early failure. Water vapor

can result in weaker bond. The moisture condition can be tested by taping a 18-ft by 18-ft polyethylene sheet on the concrete surface (ASTM D4263). If moisture collects under this sheet in less time that it takes for the epoxy to cure, the substrate should be allowed to dry before application of resin. Many states specify a 2-hr time frame for the plastic sheet test.

The aggregates used in polymer overlays should be resistant to fracturing and polishing. Suitable aggregates include pure aluminum oxide, emery, basalt with aluminum oxide, or greywacke (Smith, 1991). Aggregates should also be dry and free of dust.

UV radiation absorbed by polymers can cause scission reactions, causing molecules to break up and erode (Nelsen, 2005). In typical bridge deck overlays, the polymer is shielded from UV radiation by the surface aggregates. However, UV resistance is still a factor that should be considered.

In northern deicing states, such as Wisconsin, there is significant potential for snow plow damage to the polymer overlay. The damage is in the form of wear and reduction of skid resistance over time. Evans (2010) noted that the initially high skid resistance of a proprietary overlay system reduced rapidly over a few years. Another potential damage mode may be through freeze-thaw action. Damage may potentially occur at the interface between concrete and the polymer. In general, more recent works suggest a life expectancy of 10 to 15 years when the thin polymers overlay perform as designed. Rogers et al. (2011) report a service life of approximately 10 years. There are cases, however, when the overlays did not last as expected (Soltesz, 2010).

## Sealers

To minimize and slow down the deterioration process in concrete decks in bridges, Wisconsin and other departments of transportation in the United States routinely use different types of deck and crack sealers. The most commonly used sealers contain hydrophobic agents. These sealers are either applied to the surface of concrete after it is cured (in new or older construction) or added to the fresh concrete mix (as admixture) prior to its placement. These sealers are intended to minimize the capillary action at the surface of undamaged concrete, to fill existing cracks, and to stop the penetration of contaminated water and oxygen into the concrete. Generally, the use of these sealers has been shown to be effective in reducing chloride intrusion and extending the service life of concrete decks. However, periodic re-applications of these sealers are required to counter the loss of their effectiveness (Tabatabai et al, 2009). Sealers may lose their effectiveness in bridge decks due to various factors including traffic wear, insufficient penetration depths, and improper surface treatment prior to sealer application. A recent WHRP study included assessments of sealers in the laboratory and in the field (Tabatabai et al., 2009).

## *1.2 Objectives and Scope*

The objectives of this research project were:

- 1) To explore the effectiveness and durability of thin polymer overlays with respect to restoring and protecting bridge decks, improving safety, and extending service life.
- 2) To assess and compare performance of selected thin polymer overlay systems under laboratory test conditions.
- 3) To suggest appropriate bridge deck maintenance strategies related to this research.

The scope of work included performing a comprehensive review of literature, conducting a limited survey, and designing and implementing a testing program. The survey was a follow-up to a comprehensive survey conducted under a NCHRP Synthesis study by Fowler and Whitney (2011). Selected state engineers and material suppliers were contacted and interviewed by telephone.

An experimental research program was designed and conducted to study and compare the performance of nine different overlay systems. A total of 84 reinforced concrete specimens were subjected to accelerated corrosion (saltwater exposure and imposition of an electrical potential to the reinforcing bars), freeze-thaw cycles, heat/ultraviolet/rain exposure cycles, and tire wear tests (including simulated “snow plow” passages). Application of overlays on previously chloride-contaminated concrete was also studied through exposure of two sets of specimens to increasing chloride (corrosion) levels prior to application of overlays.

A number of parameters including pull-out strength, friction, deformation due to tire passages (rutting), and corrosion mass loss were measured. The specimens were dissected at the conclusion of testing for further examination and measurement of corrosion mass loss on the top reinforcing bars. In addition, initial friction tests were performed on four thin polymer overlay systems installed in 2013 on a Marquette Interchange ramp in Milwaukee, WI.



## 2.0 LITERATURE REVIEW

The research team conducted a comprehensive review of available domestic and international literature concerning application of appropriate overlays and sealers for bridge decks. On-line sources of information as well as conventional search databases were utilized.

A summary of the work on deck protection and repair (until 1993) was presented in a Strategic Highway Research Program (SHRP) research report (SHRP S-344 by Sprinkel et al, 1993). The SHRP S-344 study made detailed observations and recommendations on deck overlays and sealers. This study projected that, in areas of moderate deicing salt applications, the time to reach a chloride content of 1 lb/yd<sup>3</sup> is 13 years without any protection, 25 years with a maintained epoxy sealer, and 77 years with a maintained polymer overlay. Although this comparative projection of 77 years may be questionable, it does show that early results were very promising.

Some of the other observations and recommendations in this SHRP study included the following (Sprinkel et al, 1993):

- Silane-treated decks have higher permeability in the traffic lane than in the shoulders. This SHRP observation implies the need for re-application of sealers to maintain protection.
- “Multiple-layer epoxy and epoxy-urethane and premixed polyester overlays can provide a skid-resistant wearing and protective surface for 25 years when exposed to moderate salt application rates and light traffic”.
- While bond decreases with age, multiple-layer epoxy overlays exhibit the best long-term adhesion;
- Quality of aggregates is important. No. 8 gap graded basalt or silica aggregates should be used in multi-layer polymer overlays.
- Concrete with chloride content of more than 1 lb/yd<sup>3</sup> should be removed to achieve longer service life.
- “Good skid numbers are achieved when sealers are placed on tined or grooved concrete surfaces so long as the material does not fill the groove”.

Wilson et al (1995) reported on Washington State Department of Transportation’s (WSDOT’s) 10-year experience with epoxy and methyl methacrylate (MMA) thin polymer deck overlays. According to that report, WSDOT normally uses a 1.5-in-thick modified concrete (either latex or microsilica) as its primary deck overlay. WSDOT considers such overlays more durable than thin polymer overlays. However, when

additional deadweight is a problem or when the roadway width is narrow, WSDOT uses 3/8-in thin polymer overlay. Wilson et al. concluded:

*“The latest bond tests on several bridges show that epoxy overlays have a higher average value (274 psi) over time compared to MMA overlays (143 psi). The latest friction numbers show MMA overlays retain friction resistance very well over time, from an initial average value of approximately 40 to a value in the mid-30s after nine years of service. Test results show that the initial friction numbers for epoxy overlays start around 70 and fall to the mid to low 20s in five to seven years.”*

The literature search performed in this study did not indicate any agency using a combination of a first epoxy layer followed by a second MMA layer. Such a combination was chosen as an overlay system to be tested in this research. Wilson et al (1995) stated that additional polymer applications may be needed in 5-10 year intervals. They concluded that thin polymer overlays are a viable alternative to rigid concrete overlays when rapid construction is essential or when additional dead load is unacceptable.

Pfeifer and Kowalski (1999) discuss two thin polymer overlay applications on adjacent bridges carrying I-57 near Clifton, Illinois. These overlays consisted of two layers of aggregate embedded in epoxy with a total thickness of 0.25 in. A rhyolitic stone aggregate (“trap rock”) was used. Bottom and top layer aggregates had average particle sizes of 1/16 in and 1/8 in, respectively. Other requirements were that more than 5% of aggregates may pass #20 sieve, and those passing #200 sieve must be less than 1%. Skid resistance tests (with treaded and smooth tires) were performed at 4 weeks, 10 months and 20 months after installation. Initial skid numbers were 70, which over 20 months reduced to 51 (smooth tire) and 60 (treaded tire). Cores removed from these decks had average chloride levels of 2.6 lbs/yd<sup>3</sup>. The authors recommended that an application be first made on a test area, and pull-off testing (Appendix A procedures in ACI 503R) be performed within 48 hours after the test area application.

Nelsen (2005) discussed polymer deck overlays in details including resin types and failure modes. Soltesz (2010) evaluated thin overlays for bridge decks in Oregon. According to the author, Oregon has had mixed results with thin polymer overlays. Eight different thin polymer overlay systems were evaluated in the laboratory and on two bridge decks. There were installation and crew experience issues for some products. Skid testing using a skid trailer was performed in the field (ASTM E 274). Overlay applications were done in 2007 and last skid testing was performed in 2010. Laboratory flexural and compressive strength tests were performed on the overlay in accordance with ASTM C 580 and C 579. Test temperatures were 0, 70, and 140 degrees Fahrenheit. According to Soltesz, “none of the overlay systems showed superior

performance under moderate average daily traffic from the standpoint of maintaining good skid resistance and resisting wear through”. Three products began to wear through, one very early and the other two after 1.3 million vehicle passages. Soltesz reported that for the remaining five products, predictive models based on initial test results suggested that skid would reduce to 40 within five months at a traffic level of 10,000 vehicles per lane per day. Delamination was not a problem. It should be noted that Oregon allows studded tires.

Fowler and Whitney (2011) provided a history of thin polymer overlay use in bridge decks. They reported that the first TPO applications in the 1950’s involved use of coal-tar epoxy followed by a fine aggregate broadcast. In the 1960s and 1970s oil-extended epoxy as well as polyester-styrene resins and methyl methacrylate monomer systems were utilized to improve performance. Later, products were specifically designed to address TPO problems including delamination of the overlay. Fowler and Whitney (2011) reported that lower modulus and higher elongation resins were developed to address an important factor in overlay delamination, namely thermal incompatibility between polymers and concrete.

Fowler and Whitney also summarized the work of Choi et al. (1996) on interfacial stresses between overlay and the concrete substrate. They concluded that *“overlays that are thinner and less stiff will produce smaller stresses with the same temperature change.”* Fowler and Whitney further report on the work by White and Montani (1997) in which the effect of temperature on elongation is addressed. White and Montani (1997) recommend that the elongation be tested at 40°F (minimum 20% elongation) and at 73°F (minimum 30% elongation) in accordance with ASTM D638.

## 3.0 SURVEY RESULTS

### 3.1 Previous Surveys (by Others)

The research team focused its survey work on follow-up inquiries to a national survey conducted in the NCHRP Synthesis Report No. 423 on performance of thin polymer overlays for bridge decks. The NCHRP Synthesis study was performed by David Fowler and David Whitney of the University of Texas at Austin (Fowler and Whitney, 2011). This work included a national survey of states and contractors on performance of polymer concrete on bridge decks. The researchers received survey responses from 40 states. Table 1 shows a summary of survey results in that study. Fowler and Whitney summarize results of their survey as follows:

*“The survey responses, from 40 states and seven provinces, revealed that at least 2,400 TPOs have been constructed in the United States and Canada, a fourfold increase over the number installed through 1999. Seven states and three provinces that responded have not used TPOs. Nearly all states use epoxy resins, and only California indicated that it uses predominantly polyester-styrene in premixed overlays.”*

Based on their survey, Fowler and Whitney (2011) report the following causes of TPO failures:

- *“Deck condition—in many cases, overall condition of deck probably too poor to apply overlay;*
- *Repaired areas not sufficiently dry and/or not roughened;*
- *Inadequate surface preparation;*
- *Cool damp weather during installation;*
- *Deck too damp at time of overlay installation;*
- *Construction problems;*
- *Inadequate quality control; and*
- *Use of snow chains”.*

Fowler and Whitney (2011) report the contractors’ recommendation (based on their survey) as follows:

- *“Bidders be prequalified for TPO experience;*
- *Resin manufacturer’s representative always be present, especially if warranty is required;*

- *Repairs be made using compatible polymer patching materials supplied or specified by the TPO manufacturer, which eliminates paying for traffic control twice and having to build in an extra 28 to 56 days to let the patches cure, dry, and outgas;*
- *Diamond grinding be specified for very rough decks to save on the cost of shot blasting and to minimize the resin consumption;*
- *A mandatory 4-hour curing period is too long in hot weather; 1 hour is often enough and can be verified by the impact hammer and/or screwdriver test; peak exotherm or maturity might also work to confirm the curing, especially for thicker overlays;*
- *The specifications requiring the airless spray application for high-molecular-weight methacrylate sealers and primers be eliminated because of the difficulty in keeping the spray guns calibrated; by the time the problem is discovered, considerable improperly mixed resin has been applied;*
- *TPO applications always be restricted to warm and dry periods; and*
- *Warranties for 5 years be required.”*

Fowler and Whitney (2011) report the material suppliers’ identification of problems and the suppliers’ recommendation as follows:

Problems encountered (Fowler and Whitney, 2011):

- *“Poor deck condition;*
- *Cracking and delamination of deck;*
- *Inadequate concrete cover on steel;*
- *Bidding followed by requirement that they must provide technical support on site; and*
- *Obtaining all three surface preparation requirements: clean, dry, and sound.”*

Material suppliers’ recommendations (Fowler and Whitney, 2011):

- *“Technical representatives be trained;*
- *Manufacturer’s representative be on site to oversee work;*
- *The deck be in good condition;*
- *Deck be clean and dry;*
- *Deck cleaning texture be specified as ICRI CSP 7, but can accept 6;*

- *Multiple-layer TPOs be used for epoxy systems;*
- *Minimum tensile elongation be 50% for epoxy systems;*
- *Aggregate have a Mohs hardness of 7;*
- *AASHTO Task Force 34 recommendations... be followed;*
- *For polyester systems specifications, have contractor make an investment in volumetric mixers with readouts and plural components, paving machine with automatic grade control, and shot-blasting equipment; and*
- *Specification must require experience.”*

Krauss et al. (2009) report on bridge deck overlays, sealers and treatments. As part of their NCHRP study, Krauss et al. (2009) conducted a national survey of states on various repair methods and sealers. Polymer overlays (thin-bonded polymer concrete) were included in their national survey. Twenty-three states provided responses to the survey. These were AK, CA, CO, GA, ID, IL, KS, MA, ME, MO, NM, NV, NY, OK, OR, TN, UT, VT, and WY.

The respondents identified the following advantages (Krauss et al., 2009):

- *“Quick installation and rapid return to traffic (65%)*
- *Easy installation (39%)*
  - *No modifications of approaches required*
  - *No redoing of expansion joints is required*
- *Light weight or low dead load - 7 respondents (30%)*
- *Good waterproofing and low chloride permeability - 6 respondents (26%)*
- *Durability or long life - 6 respondents (26%)*
- *Skid resistance or good friction characteristics - 5 respondents (22%)”*

Table 1. Summary of Survey Results from NCHRP Synthesis Report 423 (Fowler and Whitney, 2011).

SUMMARY OF STATES AND PROVINCES SURVEY											
State	No. Placed	First/Last Year	Future TPOs	Reasons for Use	TPO System	Installer	Warranty, Year	Failures	Specs Avail.	Comments	
AK	2	2007	Yes	l, a, w	P PM	Agency	N/A	No	No	Excessive wear in tire lanes	
AL	31	1992/1994	Yes	sf, l, a, s, w	Any	Agency	N/A	No	No		
AR	0	N/A	N/A	N/A	N/A	N/A	N/A	N/A	N/A		
AZ	No state DOT TPOs										
CA	520	1983/2008	Yes	sf, l, s, w	P PM	Contract	N/A	Yes	Sent P PM, E ML	Snow chain rutting problems	
CO	Used, but no information available										
CT	Not used										
DE	1	2007	Yes	l	E ML	N/A	N/A	No	No	Too expensive	
FL	30	2000/2003	No	w	HMWM sealer	N/A	N/A	No	No	Protect cables in segmental bridges	
GA	10	Mid-1990s/2007	Yes	sf, l, a	EU ML	Contract	10	N/A	Sent E ML		
HA	0	N/A	No	N/A	N/A	N/A	N/A	N/A	N/A		
IA	1	1986	No	Trial	N/A	N/A	N/A	N/A	No	Poor performance	
ID	2	2003/2007	Yes	sf, l, w	E ML, EU ML	N/A	N/A	N/A	N/A		
IL	24	1996/2007	Yes	l, w	E ML	Contract	N/A	Yes	Sent E ML		
KS	100+13 <sup>a</sup>	1999/2009	Yes	w, l, s	E ML	Contract	None	1	E ML	Failed due to deck contamination	
MD	1	2000	N/A	w	E ML	Agency	N/A	Small cracks	No	Worked pretty well	
ME	1	1 bridge TPO DOT Installation									
MI	100s	1995/2007	Yes	sf, l, a, s	E ML	Contract, agency	N/A	Yes	Yes	Poor bond from poor surface prep	
MS	No information available										
MN	5	2006/2007	Yes	sf, l, w	E ML	Agency	N/A	No	N/A		
MO	>300	1989/2007	Yes	sf, l, a, w	E ML, EU ML, E PM	Contract	N/A	Yes	Sent		
MT	35	1995/2000	No	N/A	N/A	Contract	N/A	Yes	No	Inspection process QC/QA difficulties	
NC	50	1975/1990	Yes	w	E ML	Agency	N/A	Yes	No		
ND	Used, but no information available										
NE	0	N/A	No	N/A	N/A	N/A	N/A	N/A	N/A		
NH	2				EU ML	Contract	Yes	Yes		Improve skid resistance, life and look of bridge	

State	No. Placed	First/Last Year	Future TPOs	Reasons for Use	TPO System	Installer	Warranty, Year	Failures	Specs Avail.	Comments
NJ	0	N/A	No	N/A	N/A	N/A	N/A	N/A	N/A	
NM	250	1995/2008	Yes	sf, l, a, s, w	E ML, EU ML	Contract, agency	5	Yes	Online	Inspection process QC/QA difficulties
NY	44	1999/2007	Yes	l, w	M PM, E ML, EU ML, P ML	Contract	N/A	Only one MMA	Sent	Wearing surface aggs
OH	147 + 15 + 1 <sup>b</sup>	1979/2006	Yes	l, s	E ML	Agency, polycarb	N/A	Yes	No	Over 100 failures in late '90s
OK	10	2003/2007	Yes	sf, l, w	E ML, EU ML	N/A	N/A	N/A	N/A	
OR	35	1981/2007	Yes	l, s, w	E ML, P PM, M PM	Contract	N/A	Yes	N/A	Mostly for traction
SC	Les Floyd, not used									
SD	0	N/A	No	N/A	N/A	N/A	N/A	N/A	N/A	
TN	3	2000/2005	Yes	sf, l, w	E ML	Contract	N/A	N/A	N/A	
TX	12	1998/2008	Yes	sf, l, a, s, w	E ML	Contract	N/A	N/A	N/A	
UT	100	2001/2007	Yes	sf, l, w	E ML	Contract	N/A	N/A	N/A	Too expensive
V.A	300	1981/2008	Yes	sf, l, a, s, w	E ML, P ML, P PM, M PM	Contract, agency	N/A	N/A	Yes	Bridge deck preservation
WV	8	1997/2007	Yes	sf, l, w	E ML, U ML	N/A	N/A	N/A	N/A	
WY	61	1990/2005	Yes	sf, s	E ML	Contract, agency	N/A	Yes	Yes	Mostly for traction
Canadian Provinces										
AB	139	1984/1998	No	N/A	N/A	N/A	N/A	N/A	N/A	Poor performance, too expensive
BC	2	1990/1991	No	N/A	N/A	N/A	N/A	N/A	N/A	Poor performance, too expensive
MB	0	N/A	No	N/A	N/A	N/A	N/A	N/A	N/A	
NB	5	2005/2007	Yes	l, s, w	E ML	Agency	N/A	Yes	N/A	
NS	0	N/A	No	N/A	N/A	N/A	N/A	N/A	N/A	
NT	1	1991	Yes	s, w	E ML	Contract	N/A	N/A	Sent	
ON	0	N/A	No	N/A	N/A	N/A	N/A	N/A	N/A	Poor performance, too expensive

NOTE: sf = restore surface friction; l = extend life of deck, including additional cover; a = restore uniform appearance of deck surface; s = restore surface to previous spalled, cracked, and repaired deck; w = waterproof deck; P = polyester-styrene; E = epoxy; EU = epoxy urethane; HMW/M = high-molecular-weight methacrylate; M = methacrylate (slurry); PM = premixed; ML = multiple lift; N/A = information not available from agency.

<sup>b</sup>147 by Ohio, 15 by counties, 1 by city, <sup>a</sup>100 by Kansas, 13 by counties.



The following were the disadvantages (Krauss et al. 2009):

- *Cost - 11 respondents (48%)*
- *Installation problems (30%)*
  - *Inadequate surface preparation can affect adhesion*
  - *Binder preparation*
- *Low durability (17%)*
  - *High traffic loads*
  - *Under the wheel path*
- *Problems occurring during installation can be difficult to correct (13%)*
- *Polymer concrete cannot be used as a replacement for bridge deck concrete (4%)*

Krauss et al. further report that the use of polymer overlays has increased nationwide, especially within the last 10 years. Massachusetts has used polymer overlays for over 25 years. Thirty percent of respondents used polymer overlays in the last 10 to 25 years ago, while thirty-nine percent used such overlays beginning 5 to 10 years ago. Twenty-six percent of respondents began using polymer overlays in the last five years.

The mean and median anticipated lifespan of the polymer overlays, as reported by the respondents, were 9 to 18 years and 10 to 18 years, respectively. Table 2 shows survey responses to a question on reasons for selection of polymer overlays.

Table 2. Reasons for selection of Polymer overlays (Krauss et al., 2009).

<b>Reasons for Selection of Polymer Overlays</b>	<b>Yes</b>	<b>No</b>
Easy to install	16	7
Long anticipated service life	9	14
Good track record on similar projects	12	11
Already approved by your department	11	12
Recommended by a colleague	3	20
Research findings were positive	12	11
Inexpensive	7	16
Short lane closures (rapid return of traffic)	20	3
Dead load considerations	16	7
Personal experience	6	17
Presentation by manufacturer's representative	6	17

Table 3 shows the respondent’s answers to a question on deck conditions that can be addressed by polymer overlays. Polymer overlays were most commonly used for decks with cracking, but otherwise in good condition with no significant corrosion (15 or 65%). Polymer overlays are also used for other conditions including for newer desks.

Table 3. Deck conditions that can be addressed by polymer overlays (Krauss et al, 2009).

<b>Existing Deck Conditions Addressed by Polymer Overlays</b>	<b>Yes</b>	<b>No</b>
Newer deck in good condition (preventative)	11	12
Deck with cracking in good condition with no significant active corrosion	15	8
Deck with cracking and active corrosion (<5% delamination, no spalling)	9	14
Deck with cracking and active corrosion (>5% delamination and some spalling)	6	17
Deck with cracking and active corrosion (>10% spalling/patching)	6	17
Deck with surface deterioration or abrasion loss	10	13

Table 4 shows the survey responses regarding surface preparation used. The most common surface preparation is shot blasting. Table 5 shows responses related to surface evaluation prior to installing the overlay.

The following general recommendations made by the respondents in the Krauss et al (2009) study:

*“Three respondents recommended that a manufacturer’s representative be on site during installation. Three respondents mentioned surface preparation concerns. More than one respondent mentioned that high quality surface preparation is essential, and that a dry surface should be obtained. Another mentioned that the system does not adhere well to green concrete. Two respondents discussed cure time, one stated that cure time can be more than four hours per layer, the other to recommend use if construction time is a concern. Weather can be a factor in the cure of some systems, and it is suggested that installers adhere to temperature and humidity tolerances. One respondent recommended that thin bonded epoxy overlays not be used to repair decks with active corrosion, and another respondent recommended that polymer concrete not be used for partial replacement of a bridge deck section. This respondent also recommended the use of volumetric mixing trucks and paving machines for placement on large areas. Another respondent recommends that one should determine if cracks are working and determine ride quality. Another respondent recommends that colleagues avoid methyl methacrylate thin bonded overlays.”*

Table 4. Surface preparation techniques in polymer overlays (Krauss et al, 2009).

<b>Surface Preparation Techniques for Polymer Overlays</b>	<b>Yes</b>	<b>No</b>
No preparation	0	19
Air sweep	3	16
Broom	3	16
Sand blast	5	14
Shot blast	16	3
Water blast	1	18
Water/grit blast	0	19
Hydrodemolition	1	18
Milling	4	15
Crack routing	1	18

Table 5. Surface evaluation prior to installing polymer overlays (Krauss et al, 2009).

<b>Methods Used to Evaluate Prepared Substrate for Polymer Overlays</b>	<b>Typically</b>	<b>Occasionally</b>	<b>Never</b>
Visual inspection	17	0	0
Hammer or chain sounding	11	0	1
Adhesion test to the bare substrate	10	3	3

### **3.2 State Survey Results – This Study**

The research team contacted Prof. David Fowler to obtain detailed survey responses from his NCHRP synthesis study. Prof. Fowler provided such responses from Iowa, Minnesota, Missouri, and New York. The project team was able to contact respondents in Iowa, Illinois, Minnesota, and Missouri to ask detailed questions about their state’s experiences. Furthermore, the research team contacted several manufacturers of thin polymer overlay products to discuss applications of their products in detail.

The following is a summary of telephone conversations (in 2013) with select state DOT personnel who had responded to the earlier NCHRP survey, and whose detailed responses were received from Prof. Fowler.

#### Missouri: (Ms. Jen Harper)

As of the time of the NCHRP survey (2008), Missouri had reported over 300 TPO installations. However, Missouri has installed very few since the NCHRP survey. The reason for this major change is related to the new requirements for TPO installations. Past failures had brought about new criteria for utilization of TPO requiring that the deck delamination and damage be less than 5%. This requirement has significantly reduced the number of TPO installations since TPOs are typically not employed in a preventive mode on better deck conditions.

Missouri uses a 2-lift epoxy system with a sand broadcast, and does not use premixed systems. Missouri may sometimes use a MMA sealer prior to placement of TPO. Missouri's specifications require pull-out and moisture tests, and limit types of aggregates and gradations to be used. Missouri used to perform skid resistance tests, but does not do so anymore, and has not tested for changes in skid resistance over time. Missouri requires a 20% elongation on the epoxy resin.

Illinois: (Mr. Gary Kowalski)

In 2008, Illinois had reported a total of 24 TPO installations between 1996 and 2007. Illinois has since installed 10 more TPO systems. Illinois requires that the deck be in "good shape", and prefers that any patching be done ahead of time. The type of binder used is low-mod epoxy. MMA is not used as TPO binder, but is used for waterproofing. Illinois requires that the deck be shot-blasted and pull-out tests be performed at 3 locations with strength greater than 175 psi. Illinois requires "no visible moisture on surface" at installation.

Regarding aggregates, crushed basalt and aluminum oxide with gradation requirements are allowed. A hardness of at least 6 is required (on Mohs scale). Some of the early problems in other states have been due to use of bottom coal slag, which is not allowed for TPO applications in Illinois anymore.

Illinois did not report problems with UV resistance, skid resistance or overall TPO failures. Localized failures in wheel lanes were mentioned. Illinois has six pre-approved products for TPO applications.

Iowa: (Mr. Norm McDonald)

In the 2008 NCHRP survey, Iowa had reported one TPO installation, and reported that it had stopped using TPOs. The single TPO was installed in 1986. The deck performed well for 4 years, but later delaminated. There was another failure of TPO on another city bridge in Iowa. The TPO was installed in 1987 and failed in 1991. Cores were taken, which showed shallow delamination below bottom of overlay. Iowa plans to install another TPO next spring, and has developed a new set of specifications for TPOs. They require pull-out tests (250 psi) and specify "no visible moisture" on concrete surface. A 2-hr taped plastic test is performed for moisture indication (ASTM D4263).

Minnesota: (Mr. Ed Lutgen)

The first five TPO bridge decks (in 2006) were a proprietary system with limestone aggregates. They developed skid problems. In 2009, two bridges received a different overlay system with a taconite aggregate from Virginia. However, the aggregates dislodged because the aggregates were dirty and they were not dry. In 2012, they installed a premix polyester system with a cost of about \$12/sq ft. There was

some spalling near joints, but there were no other problems reported. In 2011, two epoxy-urethane overlay installations were made. Minnesota has not used a methacrylate system.

Minnesota does not have established criteria for applying TPOs. They decide on project-by-project basis. Minnesota requires pull-off test before application of TPO (on concrete). A minimum strength of 250 psi is required. The 2-hr plastic test is used for moisture. For aggregates, they require a hardness of 6 and have an aggregate gradation requirement.

### ***3.3 Supplier Survey Results – This Study***

Material suppliers were interviewed on the telephone in 2013.

#### TK Products: (Don Kopen)

The TK2109 is the epoxy-based product for thin polymer overlays. The first layer is applied at 40 sq. ft. per gallon (thinner) and the second layer is applied at 20 sq. ft. per gallon. A thinner epoxy product TK2110 is used for sealing cracks prior to application of TK2109. There are also two other types of crack sealer, a methacrylate product (TK2414, a little thinner than TK2110), and a polyurea product (TK9030).

The elongation for TK2109 is 36%. States prefer angular aggregates. “Trap rock” (from Kansas City) and “Red Flint” (from Eau Clair – not as angular) are sometimes used. Aggregate should be dry with less than 17% moisture (measured using a 2-needle probe). Pull-off tests are not done on jobs, and they haven’t done any tests.

Regarding surface treatment, shot blasting is very good as the epoxy can wet the surface.

The most common system is a 2-lift system. The expected life is at least 15 years. As soon as epoxy goes down, there should be another crew behind it placing aggregate. Set time is about 4 hours at 70 degrees. If there is too much delamination on the deck slab, do not place the overlay.

#### SIKA (Craig Frier):

Their product for thin polymer overlays is “Sikadur 22 Lo-Mod”, which is an epoxy-based system. They have two products for crack sealing: “SikaPronto 19TF” has very low viscosity and can be applied in colder temperature. “Sikadur 55 SLV” is another crack sealer, which cannot be used at or below 40 degrees.

The first and second layers are placed at 40 and 20 sq. ft. per gallon, respectively. Pull-off tests can be used before (to check substrate) and after overlay placement. Moisture is normally not a problem except when fresh patches exist. Moisture test can be with the plastic sheath method, probes, or calcium chloride

test. A clean and sound surface must be present. There are no problems with putting overlay on patched surfaces that are cured.

Wisconsin requires a more angular aggregate. Moisture content of aggregate is tested. The state requires independent field testing. The state may also remove cores to measure thickness.

Only one overlay delamination has been reported in 60 cases. Overlay can break down near expansion joints, but that is easy to repair.

#### Dayton Superior (Unitex): (Don Edwards)

Their “Pro-Poxy” product for thin polymer overlays is an epoxy-urethane-based product. They have a crack sealer product (“Bridge Seal”), which is an epoxy-based healer/sealer or primer. They also provide a system for skid resistance in which typically one lift is used.

The causes of problems are bad installation and contaminants. Pull-off testing only gives indication in the particular measurement area. Aggregates are provided by contractors. Typically, bauxite or flint rock is used. Moisture content of substrate measured using a moisture meter should be less than 4%.

#### International Coating (Mike Kramer):

They have an epoxy overlay system and a crack sealer/filler product that can be used with the overlay. The overlay has a ¼-in thickness in two lifts. Each lift includes 25 sq. ft./ gallon (approximately 60 mils).

The epoxy elongation is 40% but can be lower at colder temperatures. Preparation of slab is important (shot blasting). The “no standing water” rule is OK. Substrate moisture is not an issue on bridge decks. Moisture tests can be done using the calcium chloride method, the relative humidity test, or the plastic sheet method. A pull-off test is not necessary, but 250-300 psi pull-off strength is standard. Coatings over patched areas are OK as long as there is a solid surface. Regarding aggregates, the manufacturer does not supply aggregates, and whatever the state requires in its specifications is followed.

#### Kwik Bond Polymers (Greg Freeman):

The company provides premixed and multi-lift polyester overlay systems. They have worked with Caltrans for many years (1970s). In the last 6-8 years, multi-lift polyester with slightly modified polyester is also used.

The premixed polyester overlay is considered to be a better system. The premixed system has to have trained contractors. Most states have multi-lift specifications, and there is market demand for multi-lift systems. Polyester has better UV stability, better thermal compatibility, and shorter time is needed to

return traffic. Calcined bauxite aggregate (from aluminum smelting) would be the best type of aggregate because of its polished stone value (PSV) test results. This aggregate is imported from overseas and is processed in the US. They require visibly surface dry conditions for the substrate. Pull-off tests results are expected to be over 300 psi. They expect skid resistance in 5 years of over 65. On patched systems, some patches could have off-gas that affects good bond. Cured properties are important.

### **3.4 Summary of Survey Results**

A comprehensive survey related to thin polymer overlays was conducted by Fowler and Whitney in 2011. Therefore, instead of conducting a new survey, the research team focused on reviewing the existing survey, and seeking follow-up feedback from those who had responded to the initial survey. Engineers from departments of transportation in Missouri, Illinois, Iowa, and Minnesota were contacted for telephone interviews. In addition, suppliers of polymer overlay materials were contacted and interviewed to obtain feedback. The following summarizes some of the survey results

Causes of overlay failure include:

- Improper surface preparation
- Surface moisture
- Out-of-range concrete temperature
- Deck patch materials that have not sufficiently aged
- Unsound concrete deck surface
- Pre-existing corrosion deterioration and chloride contamination

Recommendations:

- Specifications should address surface preparation procedures and outcomes.
- Specifications should address hardness (Mohs scale), gradation, shape, dryness, and cleanliness of aggregates.
- Specifications should address thermal compatibility between the polymer and the deck concrete as well as minimum strength and elongation properties for the polymer.
- Quality control procedures should include pull-out strength, moisture (dryness) tests, and surface temperature measurements.
- Experience of crews and/or presence of experienced supplier representative are considerations in quality control.

## 4.MATERIAL SELECTION AND EXPERIMENTAL DESIGN

### 4.1 Material Selection

A list of available commercial products for thin polymer overlays and crack sealers that are commonly used in conjunction with polymer overlays is shown in Table 6. Based on the evaluation of available literature, surveys, and discussions with state DOTs and manufacturers, the research team proposed nine sets of different products/methods/materials (treatment systems) for testing. These overlay systems were designated S1 through S9. The research team's proposed treatment selections were presented to the project oversight committee and approved. One set of control specimens (without any overlay) were also used (designated S0). Table 7 shows the various treatments that were tested.

The treatments used included the primary generic polymer types that are commercially available (two low-modulus epoxy products, an epoxy-urethane, and a polyester styrene). The baseline polymer used was a low-mod epoxy. Three types of aggregates were used with the baseline polymer: flint rock, Wisconsin granite, and calcined bauxite. The baseline aggregate used was flint rock. All commercially-available aggregate types that were used in this study had been graded and prepared by their suppliers for the purpose of use in thin polymer overlay applications. Treatment S1 had the baseline polymer resin (epoxy) and the baseline aggregate (flint rock) used in the 2-lift overlay. Treatments S2 and S3 were designed to compare Wisconsin granite (S2) and calcined bauxite aggregates (S3) with the flint rock aggregate since all three treatments (S1, S2, and S3) had the same low-mod epoxy resin.

It should be noted that the calcined bauxite aggregates used for high friction surface treatment (HFST) of pavements are typically required to have a minimum aluminum oxide content of 87% (measured using procedures in ASTM C25). In general, specifications on thin polymer applications for bridge decks do not have such a requirement. The calcined bauxite aggregates used in this study had material test reports indicating compliance with the 87% aluminum oxide requirement. However, energy dispersive X-ray spectroscopy (SEM/EDS) tests performed after the conclusion of the experimental program indicated aluminum contents that were below the prescribed limits for HFST.

Treatment S4 had a first layer of the baseline epoxy and a second methacrylate layer. Both layers used Flint rock as aggregate. Treatment S5 had two layers of the baseline epoxy. However, the second (top) epoxy layer was modified by adding Flue Gas Desulfurization (FGD) gypsum powder (air dried) at a weight fraction of 70% of resin. FGD gypsum is a byproduct of burning coal in electric power plants. Previous research at UWM indicated that such an additive improved mechanical properties of polyesters.



Treatment S5 had Flint rock for both layers. Treatment S6 had two layers of an epoxy-urethane resin with calcined bauxite aggregate as a manufacturer's choice of aggregate for this product.

Treatment S7 was a pre-mixed polyester-styrene system in which aggregates are pre-mixed with the polymer and then placed on the surface of concrete. Aggregates were part of the system supplied by the manufacturer and therefore the aggregate type is not specified in Table 7. This was the only premixed product used in this research.

Treatment S8 was a polyester multi-lift system. Two layers of polyester resin with flint rock were used. Finally, Treatment S9 was added to the test program as an additional treatment tested under a separate contract with the manufacturer. A fourth aggregate type, taconite, was used only in conjunction with the S9 overlay system since the manufacturer wished to use that aggregate type as part of their system. The resin type used in S9 was identified as a low-mod epoxy. Additional information on various overlay products are shown in Table 8.

## **4.2 Laboratory Testing Procedures**

### **4.2.1 Test Specimens**

The laboratory experimental plans included tests to evaluate the effects of freeze-thaw cycles, tire passages, and heating/cooling/ultraviolet exposure on surface friction, bond to concrete, and reinforcement corrosion. The test specimens used were concrete blocks with the overall dimensions of 15 in x 15 in x 4 in. The concrete material was a conventional WisDOT mix design for bridge decks. Specimens includes four No. 5 bars (two at the top layer and two at the bottom layer) as shown in Figure 1. The cover distance to the top surface was 1.0 in. instead of the commonly-used bridge deck cover of 2 in to accelerate chloride penetration during corrosion testing. All specimens were tined (grooved) in accordance with standard practices.

Figure 2 shows specimen molds before casting concrete, and cast specimens before and after tining their top surface. All specimens were cured by covering with plastic sheathing for one week. All specimens were more than 28 days old when overlays were applied.

The total number of test specimens was eighty-four (84). There was one additional slab specimen for each overlay system to allow pull-off testing and baseline chloride measurements at the beginning of tests. Initial bond pull-out tests (in accordance with ACI 503R – Appendix A procedures) was conducted within 48 hours of overlay application. Prior to exposure tests, all specimen surfaces (except the top surface)

were coated with an epoxy paint so as to limit moisture movements into or out of the specimens except through the top surface (overlay).

The specimens were grouped and numbered as shown in Table 9. The specimen numbering system contains information on the overlay system (type of overlay, S1 through S9, with S0 used for control specimens), extent of pre-existing corrosion/chlorides (Groups A, B, or C), and specimen number (1 through 3). For example, S4-B2 refers to the second specimen with overlay type S4 and moderate corrosion/chloride exposure condition (Group B).

Table 6. Commercially available products for thin polymer overlays.

<b>Manufacturer</b>	<b>Product Trade Name</b>	<b>Generic Type</b>	<b>Usage</b>
BASF	Trafficguard EP35	Epoxy	Overlay
Dayton Superior	Pro-Poxy Type III	Epoxy and Urethane	Overlay
Dayton Superior	Bridge Seal 75%	Epoxy	Crack Sealer
International Coating, Inc.	ICO Flexi-Coat BD	Epoxy	Overlay
International Coating, Inc	ICO-Gel	Epoxy	Crack Sealer
Kwik Bond	PPC MLS	Polyester	Overlay
Kwik Bond	PPC 1121 MM MIX	Polyester premixed	Overlay
Poly Carb, Inc.	Mark 154 Safe-T-Grid	Epoxy	Overlay
Poly Carb, Inc.	Mark 163 Flexogrid	Epoxy and Urethane	Overlay
Sika Corporation	Sikadur 22 Lo-Mod	Epoxy	Overlay
Sika Corporation	SikaPronto 19 TF	Methacrylate	Crack Sealer
Sika Corporation	Sikadur 55 SLV	Epoxy	Crack Sealer
TK Products	TK 2109	Epoxy	Overlay
TK Products	TK-2110	Epoxy	Crack Sealer
TK Products	TK-2414	Methacrylate	Crack Sealer
TK Products	TK-9030	Urethane/Polyurea Hybrid	Crack Sealer
Transpo	Transpo T-48	Polysulfide Epoxy	Overlay

Table 7. Selected Test Products/Methods.

<b>Specimen</b>	<b>Product</b>	<b>Broadcast Aggregate</b>
S0	Control – no overlay system	-
S1	low-mod epoxy 1 (2 lifts)	flint rock
S2	low-mod epoxy 1 (2 lifts)	Wisconsin granite
S3	low-mod epoxy 1 (2 lifts)	Calcined bauxite*
S4	low-mod epoxy 1 (1 lift) + methacrylate (1 lift)	flint rock
S5	low-mod epoxy 1 (1 lift) + low-mod epoxy 1 augmented with additive (1 lift)	flint rock
S6	Epoxy-urethane (2 lifts)	Calcined bauxite
S7	Polyester styrene (premix)	NA
S8	Polyester styrene (2 lifts)	flint rock
S9	Low-mod epoxy 2 (2 lifts)	Taconite

\*This calcined bauxite aggregate did not meet the HFST requirement for aluminum oxide content.

Table 8. Product information provided by suppliers for various polymer overlay products.

Low-mod epoxy 1	A 2-component (1:1 by volume), 100% solids, moisture-tolerant, epoxy resin binder; tensile strength: 2650 psi, elongation at break: 55%; Shore D hardness: 72; water absorption: <0.2%; compressive modulus: 40,000 psi.
Epoxy-urethane	A 2-component (2:1 by volume), 100% solids, epoxy-urethane resin binder; tensile strength: 2700 psi, elongation at break: 35-45%; Shore D hardness: 55-75; water absorption: 0.3-0.5%; tensile modulus: 70,000-80,000 psi.
Polyester premixed	A polyester-based polymer overlay; tensile strength: >2500 psi; elongation at break: >35%; system compressive strength: >4000 psi; flexural strength: >1600 psi.
Polyester multi-lift	A hybrid polymer system; tensile strength: 2650-3900 psi; elongation at break: 30-40%; system compressive strength: >5000 psi; flexural strength: 4000-4600 psi.
Low-mod epoxy 2	A 2-component (1:1 by volume), 100% solids; tensile strength: 2500 psi, elongation at break: 45%-55%; Shore D hardness: 71; water absorption: <1.0%.

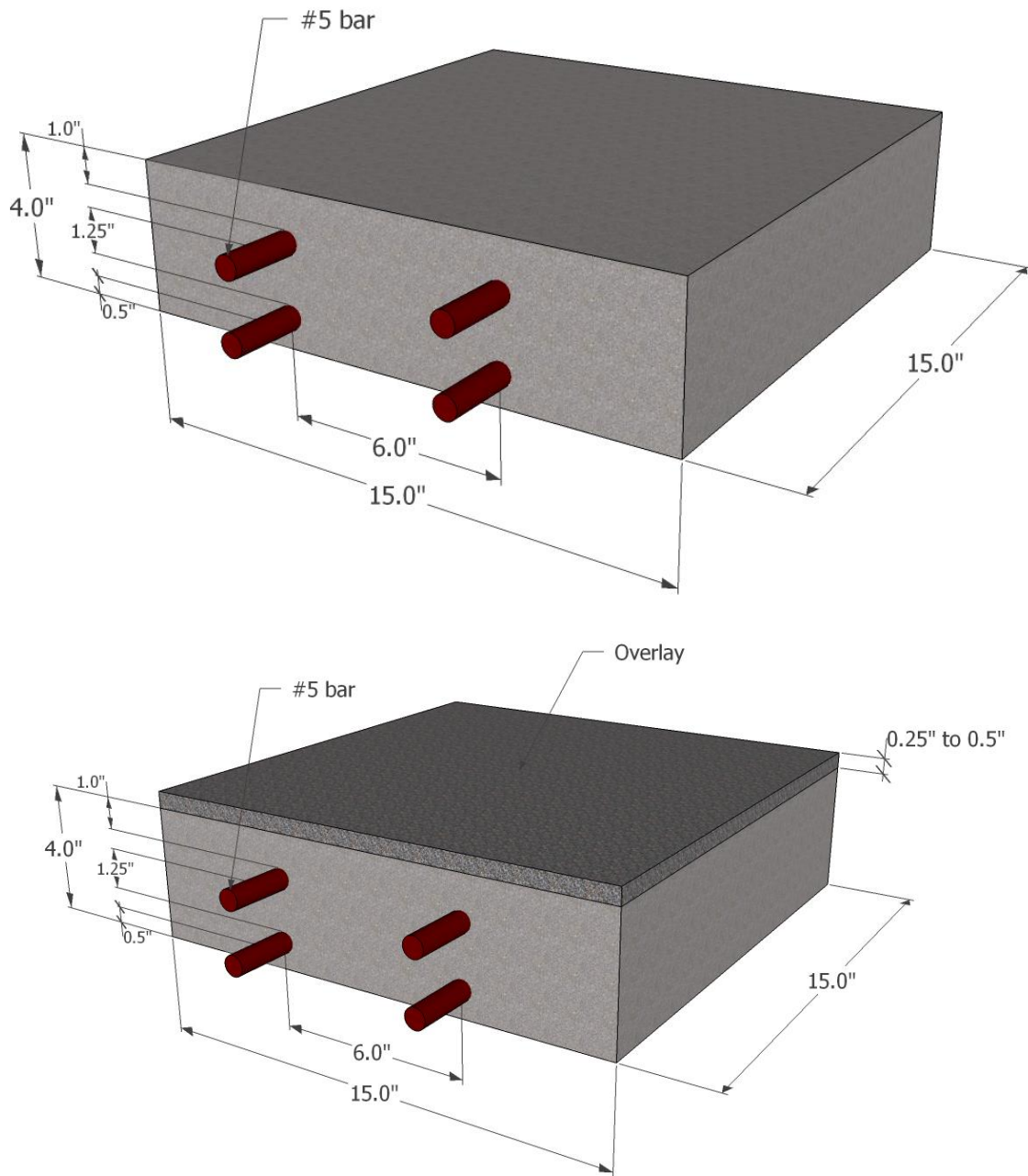

Figure 1. Concrete test specimen (with and without overlay).

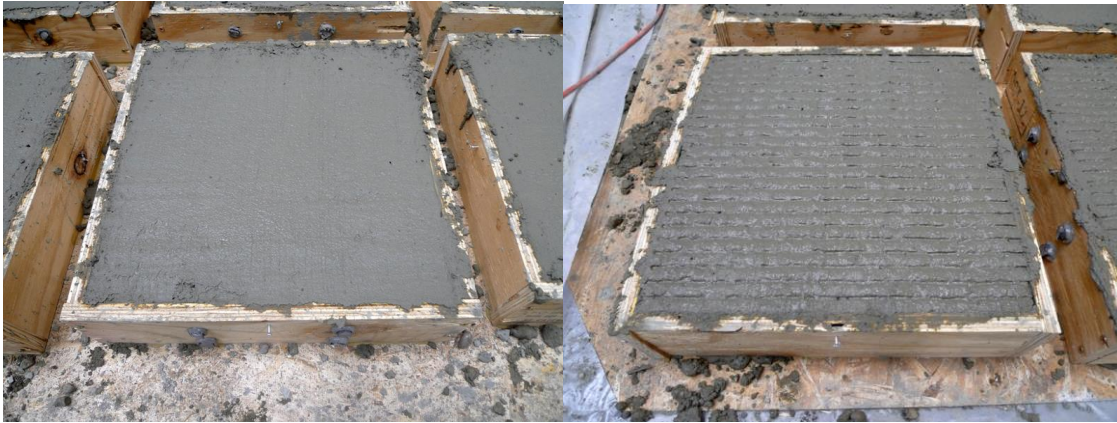

Figure 2. Concrete specimen preparation.

Table 9. Grouping of test specimens.

Type of treatment	Group A			Group B			Group C		
<b>S0</b>	S0-A1	S0-A2	S0-A3						
<b>S1</b>	S1-A1	S1-A2	S1-A3	S1-B1	S1-B2	S0-B3	S1-C1	S1-C2	S1-C3
<b>S2</b>	S2-A1	S2-A2	S2-A3	S2-B1	S2-B2	S2-B3	S2-C1	S2-C2	S2-C3
<b>S3</b>	S3-A1	S3-A2	S3-A3	S3-B1	S3-B2	S3-B3	S3-C1	S3-C2	S3-C3
<b>S4</b>	S4-A1	S4-A2	S4-A3	S4-B1	S4-B2	S4-B3	S4-C1	S4-C2	S4-C3
<b>S5</b>	S5-A1	S5-A2	S5-A3	S5-B1	S5-B2	S5-B3	S5-C1	S5-C2	S5-C3
<b>S6</b>	S6-A1	S6-A2	S6-A3	S6-B1	S6-B2	S6-B3	S6-C1	S6-C2	S6-C3
<b>S7</b>	S7-A1	S7-A2	S7-A3	S7-B1	S7-B2	S7-B3	S7-C1	S7-C2	S7-C3
<b>S8</b>	S8-A1	S8-A2	S8-A3	S8-B1	S8-B2	S8-B3	S8-C1	S8-C2	S8-C3
<b>S9</b>	S9-A1	S9-A2	S9-A3	S9-B1	S9-B2	S9-B3	S9-C1	S9-C2	S9-C3

#### 4.2.2 Introduction of Initial Chlorides

For each of the nine overlay systems, three different corrosion/chloride exposure levels were considered. Prior to the application of overlay, the test specimens were divided into three Groups A, B, and C. Group B and C specimens were subjected to 6% saltwater exposure and an electrical potential of 2 volts between top and bottom bars (similar to the accelerated corrosion procedures discussed later). Group B and C specimens were exposed to 1 and 2 weeks of accelerated corrosion exposure, respectively. Each week consisted of 4 days of wet condition (saltwater on top surface) and 3 days of dry surface conditions (saltwater removed from top surface) while an external constant voltage of 2 volts was applied. The application of electrical potential (making top bars anodic) accelerates reinforcing bar corrosion as well as penetration of chloride ions into the concrete. Figure 3 shows specimens undergoing initial chloride/accelerated corrosion exposure prior to the start of exposure tests.

The amounts of chlorides (prior to placement of overlays) under Group A, B, and C exposure conditions were measured on three slab specimens that were dedicated to these destructive chloride tests. Chloride testing was done using the Rapid Chloride Test (RCT) procedures (Germann Instruments, 2010). The RCT method has a reported average variation of  $\pm 4\%$  with respect to the AASHTO T 260 titration method (Pritzl et al., 2015).

The measured baseline acid soluble chlorides for specimens with Group A exposure was 0.023% of concrete mass (0.90 lb/yd<sup>3</sup>). The source of this chloride was the concrete ingredients themselves as there were no external chloride exposures for this group. The average measured acid soluble chlorides within the top 1 in (25 mm) of test slab in Group B and C specimens were 0.115% and 0.145% of concrete mass, respectively. Therefore, the average added chlorides within the top 1 in for Group B and C specimens were 0.092% and 0.122%, respectively. This amount is equivalent to 3.6 and 4.8 lb. per cubic yard of added chlorides in the top 1 inch of slab for the Groups B and C, respectively. It should be noted that the chloride levels in the top 1 inch (cover depth) of the test slab specimens is equivalent to the bottom 1 inch of the depth of cover (directly above the bar) in typical bridge decks with a minimum cover depth of 2 in. Therefore, Group A specimens had no added chlorides, while Group B and C specimens had ‘moderate’ and ‘high’ initial chloride levels. These groups were meant to represent different ages of concrete at which times overlays may be applied. Each test treatment/ Chloride group combination had three specimens.



Figure 3. Group B and C specimens undergoing initial chloride/accelerated corrosion exposure.

#### 4.2.3 Overlay Applications

Various treatments were applied to the 15 in x 15 in. top surface of all specimens after proper surface preparations. All manufacturers were invited to observe and monitor installation, and were offered the opportunity to apply the treatment themselves. Prior to the overlay applications, top surfaces of all specimens receiving treatments were shot blasted in a blasting cabinet. The steel shots used were S460 shots with a nominal size of 1.19 mm.

Figure 4 shows the general process of application of thin polymer overlay for one of the overlay types. For the multi-lift (2-layer) systems, the polymer components were first mixed with an electric mixer. The amount of polymer used in each layer was carefully measured based on the manufacturers' recommendations. A duct tape was placed around the top surface of the specimen to create a short "dam" for the polymer resin and aggregate placements. The liquid polymer resin was then placed and spread on the top surface of concrete. The aggregate was then spread (broadcast) on the "wet" surface until liquid was no longer visible on the surface. The resin was allowed to harden, and then a shop vacuum machine was used to remove the extra (un-bonded) aggregates from the surface. The process of mixing and placing the resin and broadcasting of aggregates was then repeated for a second time. The total thickness of the 2-layer system was on the order of  $\frac{3}{8}$  in to  $\frac{1}{2}$  in. Figure 5 shows specimens with 2-layer overlays applied on the top.

In the case of pre-mixed polyester system (S7), aggregates supplied by the manufacturer were mixed with the polymer before placement on the surface. A primer was first applied on the concrete surface. The overall thickness of this overlay was on the order of  $\frac{3}{4}$  in. The surface was finished smooth. Figure 6 shows placement of the S7 overlays.





Figure 4. Placement of thin polymer overlay on test specimen.

#### 4.2.4 Exposure Rounds

Each specimen was subjected to a sequential series of exposures/tests as shown in Figure 7. After the application of overlays, all specimens were subjected to three rounds of testing/exposure involving accelerated corrosion, freeze-thaw cycles, heat/UV/rain cycles, and wear testing (repetitive tire passage), and a “snow plow” test at the end of round 3 testing. Details of each test component are described below.



Figure 5. Multi-lift overlay placements.



Figure 6. Pre-mixed polyester overlay system (S7) placement.

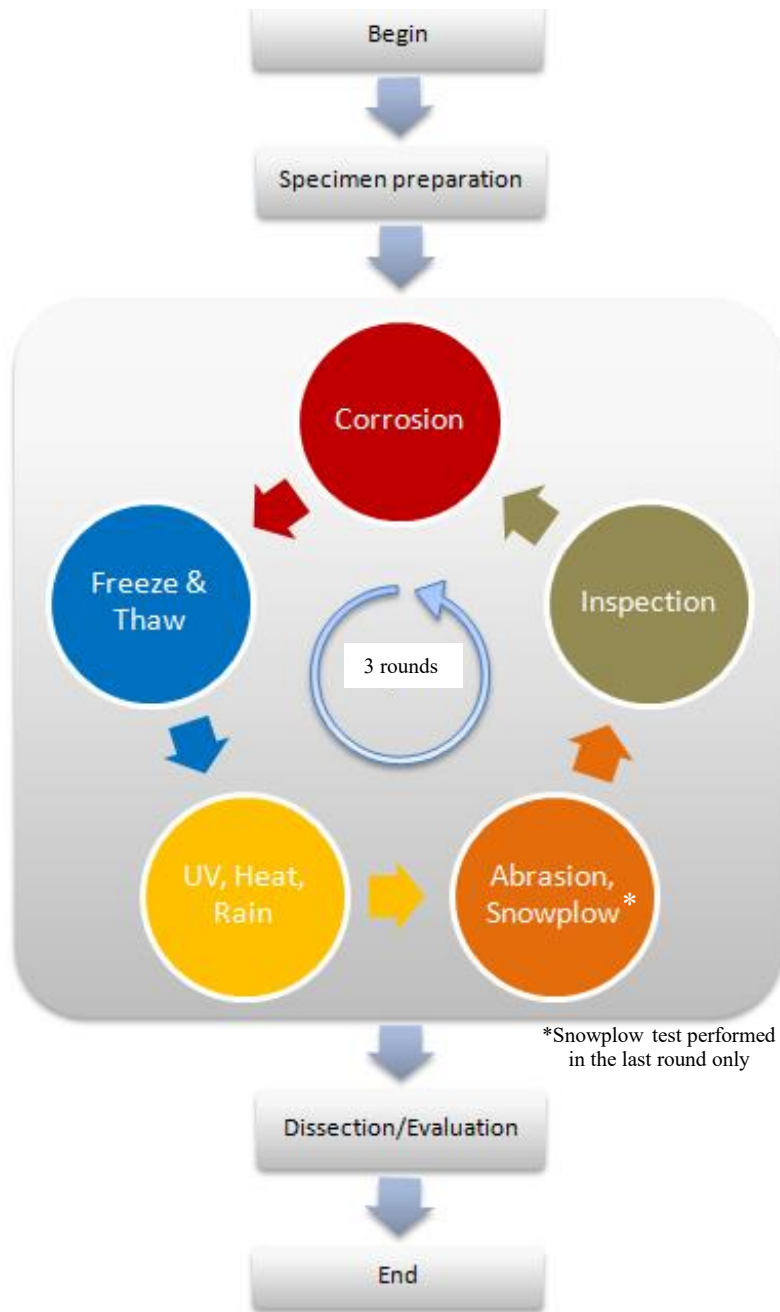

Figure 7. Test exposure cycles.

#### 4.2.4.1 Accelerated Corrosion Testing

Corrosion/chloride exposures were achieved through a combination of 6% NaCl salt ponding and imposition of an electrical potential between anode (top) and cathode bars. This approach has been used in previous WHRP research resulting in rapid penetration of chlorides and corrosion (Tabatabai et al., 2010 and Tabatabai et al., 2005).

The accelerated corrosion program was designed to test the ability of the polymer overlay and the concrete block to prevent or limit infiltration of chloride ions (introduced through road salt) and the resulting corrosion. During the exposure test, chlorides (saltwater) were introduced at the top surface of the samples. The source of the chlorides in this controlled test was food-grade salt (NaCl) dissolved in water to achieve a 6% concentration. A constant external potential of 2V was imposed between the two top bars (anode bars) and the two bottom bars (cathode bars) to accelerate the corrosion process. A regulated power supply was used to supply the constant voltage to all specimens under accelerated corrosion exposure.

Each set of accelerated corrosion test groups consisted of six specimens. The samples were arrayed in two rows of three on the testing table. Once the samples were placed in position in the accelerated corrosion station, rigid plastic sidewalls were installed around the top surface of all six specimens. Silicone caulk was used to attach rigid plastic walls to the four side walls of the specimen. Silicone caulk was needed to ensure that saltwater would not leak out from the top surface during testing.

Once the caulk was set, electrical wires were attached to the reinforcing bars within the test specimens. Each of the bars were pre-drilled at each of its two ends to create a small opening perpendicular to the axis of the bar. The opening was used to insert a connector (banana plug) and make full electrical contact between the wires and the reinforcing bars. The surface of the drilled holes was cleaned to ensure proper electrical connection prior to each accelerated corrosion round. The top bars (anode or corroding bars) and the bottom bars (cathode or non-corroding bars) were connected to the electrical circuit shown in Figure 8. The two top bars were connected together and the two bottom bars were similarly connected together as well (as shown in Figure 9).

The specimens were subjected to 7-days of accelerated corrosion testing in each of the three rounds of testing. Each week of exposure involved placement of saltwater on the top surface (wet condition) for 4 days followed by removing the saltwater (dry condition) for the remaining three days.

Figure 9 shows the accelerated corrosion testing setup under wet and dry conditions.

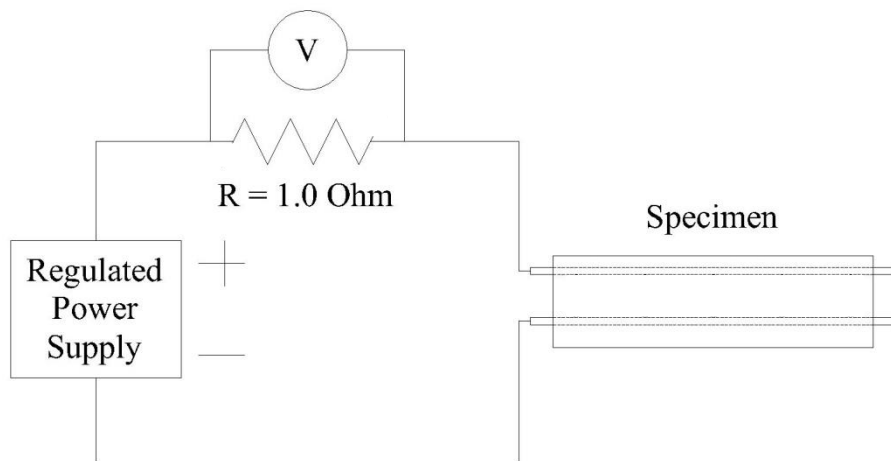
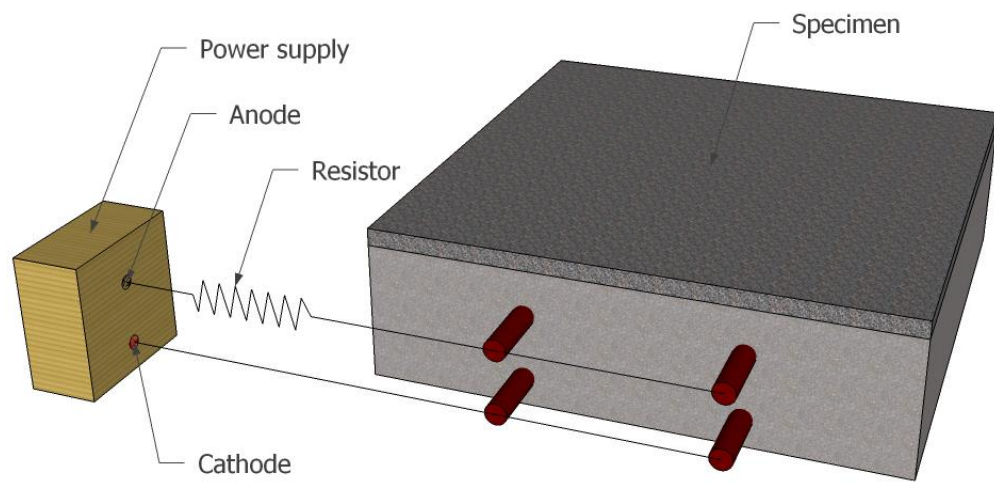

Figure 8. Accelerated corrosion setup.

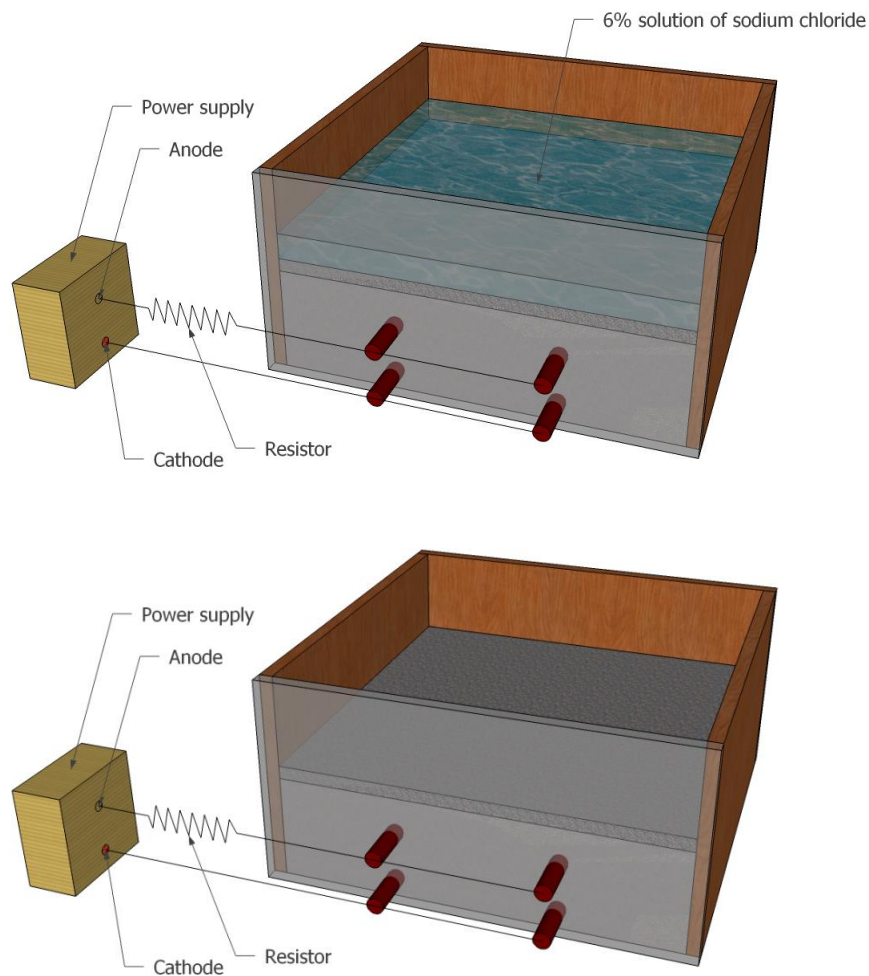

Figure 9. Accelerated corrosion exposure setup.

#### 4.2.4.2 Freeze-Thaw Cycles

Once the specimens completed each corrosion exposure round, they could begin the freeze-thaw (FT) phase of testing. The FT exposure subjected the specimens to repeated cycles of freezing and thawing to assess their effects on the durability and adhesion of the overlays. All specimens were subjected to three rounds of freeze-thaw cycles. A total of 50 freeze-thaw cycles were applied (two round of 16 cycles each and last round of 18 cycles).

A specially-designed machine with computer controls (“automated setup”) was used for the freeze-thaw tests (as well as heat/UV/rain and wear tests) during the first two exposure rounds (Figure 10). The last round of testing (round 3) involved manually moving carts loaded with specimens into and out of a freeze-room (“manual setup”) (Figure 11) to achieve the required number of freeze-thaw cycles. A total of three

carts were made for the manual setup. The use of the manual procedures was necessary after malfunction of the automated machine following the completion of the second round of testing.

The automated setup was part of custom-made test machine that was designed and constructed for this research. The automated machine had six drawers with its three lower drawers dedicated to FT testing. Each drawer was designed to receive one specimen. The heating/cooling elements were located underneath the bottom surface of each FT drawer.

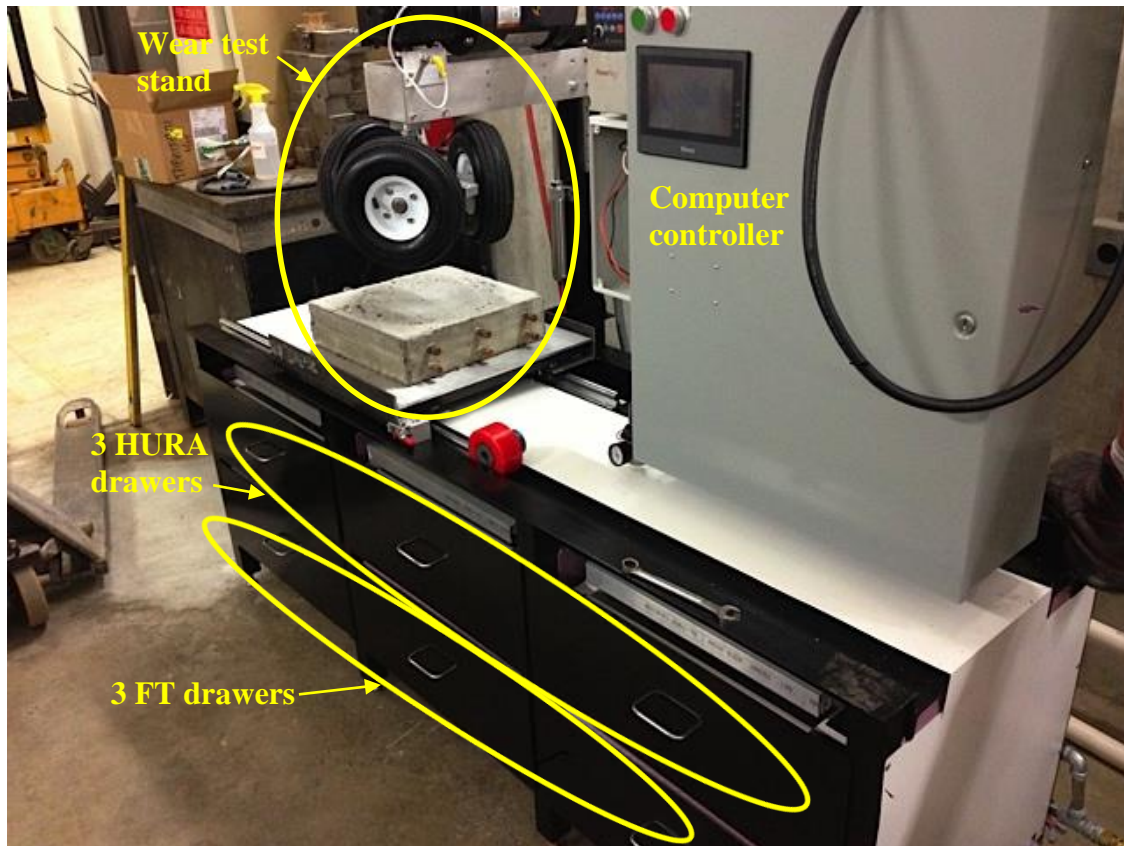

Figure 10. Automated computer-controlled machine for FT, HURA and wear testing of specimens.



Figure 11. One of the three carts used for manual FT testing.

The following procedures were followed using the automated test machine in the first two round of FT testing:

Automated Procedures (FT Procedure 1) (used in rounds 1 and 2):

- Before beginning of each round, the drawer was cleaned and any loose aggregate or standing water was removed.
- Four non-metallic washers were placed on the base of the FT drawer as supports for the specimens, and to ensure that the specimen is slightly off of the bottom.
- The specimen was placed inside the drawer with the top (overlay) surface facing down (Figure 12).
- A temperature sensor was placed on the side concrete surface just adjacent to the overlay. A piece of insulating foam was placed over the sensor thus wedging the sensor between the insulating foam and the concrete. This would allow for an accurate reading of the concrete temperature next to the overlay.
- Approximately one liter of non-salted tap water was poured into the drawer. The water would then be in contact with the overlay face of the specimen.
- An insulating lid was placed over the specimen inside the drawer.



- The desired number of FT cycles was programmed into the controller for each individual drawer. The temperature range was 10° F to 45 ° F. The machine could complete 3-4 cycles in each day.

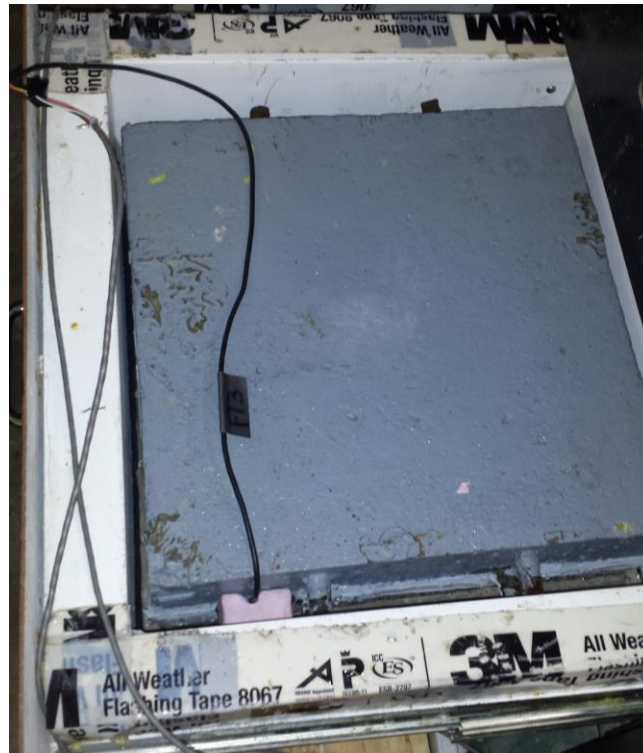

Figure 12. FT drawer with specimen placed face-down.

#### Manual Procedures (FT Procedure 2) (used in Round 3):

- Each of the three shelves on each cart was cleaned and any loose aggregate or standing water was removed.
- Four non-metallic washers were placed at the base of each shelf as supports for the specimen, and to ensure that the specimen is slightly off of the bottom of the shelf.
- Specimens were placed on the shelves of the cart with the overlay surface facing down (Figure 11). Each of the three shelves of each cart was a water-tight container that could hold two specimens.
- Two to three liters of non-salted tap water was placed in the shelves, making sure that there is a sufficient amount of water to cover the surface aggregates.
- Each cart was rolled into the walk-in freezer room. This room was set at a temperature of -10° F.
- The carts were kept in the freeze-room for 7-8 hours. The specimens were then removed from the freeze room.

- The carts were left to thaw overnight to room temperature, approximately 65°F. One FT cycle was achieved in each 24-hour day.

#### 4.2.4.3 High Temperature/UV/Rain/Ambient Temperature (HURA)

The High-temperature/UV/rain/ambient temperature (HURA) exposure tests were designed to subject the overlays to repetitive cycles of heat and ultraviolet light followed by “rain” and cooling down (Figure 13). This was intended to represent summer exposure situation when rain may follow a hot sunny day. The peak target concrete temperature during heating was 120° F (at the concrete level directly adjacent to the overlay). Four UV fluorescent lamps located at the ceiling of each HURA drawer provided ultraviolet exposure during the heating period. When temperature of concrete reached 120° F, the overlay surface was rapidly cooled by “rain” (i.e. splashing of water from the drawer’s ceiling) until concrete temperature fell below 70° F. Heating was provided using elements on the bottom of the drawer. All UV bulbs used were 25 watt, 18 in, T8 fluorescent tubes (F25T8350BL18).

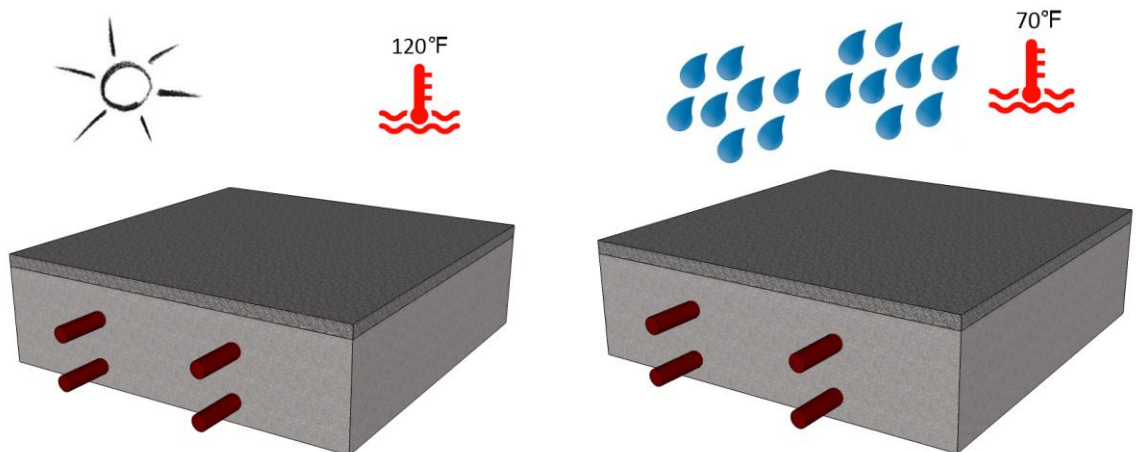

Figure 13. HURA test cycles: Heat and UV (left), rain and cool down (right).

The automated test machine described in the previous section was also used for the HURA tests (Figure 10). The three upper drawers of the test machine were used in Rounds 1 and 2 of testing. The machine was set to complete 21 cycles of heating and cooling in each round.

Due to the automated machine’s malfunction after the completion of the second round of HURA tests, a second manually-controlled box was designed and built for simultaneous testing of nine specimens. The manual device for HURA testing consisted of a custom designed wood enclosure. Unlike the automated system, temperature monitoring and release of cooling water was done by a test observer. Figure 14 shows the manual HURA test box. The removable box top had nine heat lamps (one for each specimen) and 4

UV light bulb (the same type as those used in the automated system). In addition to the heat lamps, an electric heater also provided general heating for the inside of the box through a side access duct. The top surfaces of the specimens (overlays) were cooled by a system of pipes that sprayed each specimen individually with tap water to rapidly cool the surface of the overlay.



Figure 14. Manual HURA test box.

Automated Procedures (HURA Procedure 1) (used in Rounds 1 and 2):

- HURA drawers were cleaned and any loose aggregate or standing water was removed.
- Four non-metallic washers were placed on the base of the HURA drawer as supports for the specimens. This would allow the “rain” water to drain under the specimens when the cooling cycle was engaged.
- The specimens were placed in the drawer on the washers with the overlay surface facing up (upright) exposing it to the UV lamps and the water spout.
- A temperature sensor with a splash guard was placed on the side wall of the concrete specimen adjacent to the overlay. The splash guard was used to prevent water from reaching the temperature sensor.
- The drawer door was closed and a foam insulation strip was placed over the gap in the drawer.
- Each specimen completed 21 HURA cycles.

Manual Procedures (HURA Procedure 2) (used in Round 3 only):

- Nine specimens were placed inside the box and the lid was closed.
- All lamps and the electric heater were turned on.
- Once the specimen temperature (on the side wall concrete adjacent to the overlay) reached 120 degrees, the lamps were turned off and the lid was removed.
- The cooling pipe system was placed over the box and tap water was turned on. The water was allowed to cool the specimens for roughly 10 minutes until the temperature reading reduced to approximately 70 degrees.
- The process was repeated 21 times.
- Each manual cycle took roughly 1 hour and 45 minutes.

#### **4.2.4.4 Wear Tests**

The wear test was designed to simulate the effects of vehicle tire wear on the roadway surface. A three-wheel machine for wear testing of asphalt pavements was originally developed at the National Center for Asphalt Technology (NCAT) and later refined at Auburn University (Erukulla, 2011) (Figure 15). The UWM wear test machine, which was designed for this study (Figures 16 and 17), is a modified version of the NCAT machine. The UWM machine was built into the automated test machine shown in Figure 10.

The UWM wear test machine consists of three rotating tires arranged in a circular pattern with a diameter of 12 in (i.e. the diameter of the centerline of tire path circle was 12 in.). The wheels (tires) were 10-in diameter, non-flattening, solid rubber tires with a nominal load capacity of 350 lbs. The wear machine has an adjustable speed control. A speed of 30 rpm was used for all tests performed in this research. Each round of wear testing included 11,000 turns (33,000 tire passages). The total number of tire passages for the three rounds of testing was 99,000.

During testing, the specimen is placed in an aluminum container, which acts as a cart that can move horizontally along the length of the machine. The cart can ride on a set of horizontal bearings on the top surface of the machine. The cart is first moved away from underneath the wear device head to allow placement of the specimen. The cart (and the specimen) is then horizontally slid to a position directly under the wear device. The cart is then locked in place so that it would not move during wear tests.

The machine head can be raised or lowered (on a linear bearing) using a pneumatic system. When the air pressure (holding the wear device up) is reduced to zero during testing, the weight of the entire wear

device is supported on the three tires that are placed on the specimen. The total weight of the wear device head was 114.4 lbs. The top surfaces of specimens were kept wet during the entire period of testing (using dripping tap water). Before the start of testing (Round 0) and after each completed round, the friction coefficient for the tire passage on the specimens was measured. Procedures for measuring the friction coefficients are described in Section 4.2.4.5.

The following procedures were used for wear testing:

- The specimen was placed on the friction cart (face up) directly under the wear device and secured tightly in place. The cart was also locked in place.
- Water was used to wet the top surface of the specimen, and the wear test apparatus (and tires) was lowered onto the specimen (by releasing the air pressure). The central position of the apparatus with respect to the specimen was verified (and changed if necessary). At this stage, the full weight of the apparatus was on the sample.
- The machine controller was set to perform 11,000 turns (3 tire passages per each of the 11,000 turns equals 33,000 tire passages). The speed of the turns was set at 30 rpm.
- The water supply was adjusted to achieve a steady water drip onto the top surface to maintain the surface in a wet condition for the entire duration of the test.
- When the 11000 turns were completed, the specimen cart was slid away from under the tires and the top surface of the block was cleaned with a soft brush and water to remove any tire residue that may have accumulated.
- One of the three tires was removed from the head apparatus, and the friction test hardware was inserted in its place. The electrical wires from the test hardware were then plugged in.
- The specimen was examined for on any cracks, delamination, or other changes that may have occurred during the previous round of testing.
- The specimen cart was slid back under the head apparatus and locked in place. The friction test wheel was then lowered onto the surface of the specimen.
- The computer data acquisition system designed to capture load cell (torque) data due to friction was turned on, and the friction test wheel brake assembly was powered.
- The wear test machine was turned on to start the turning of the friction wheel assembly.
- A control button was used to temporarily lock the brakes on the friction wheel. This button was pressed 12 times or more at approximately 5 second intervals. High-speed force readings were made using the data acquisition system.

- The specimen was then removed from the test machine, and the data were recorded for further analysis.

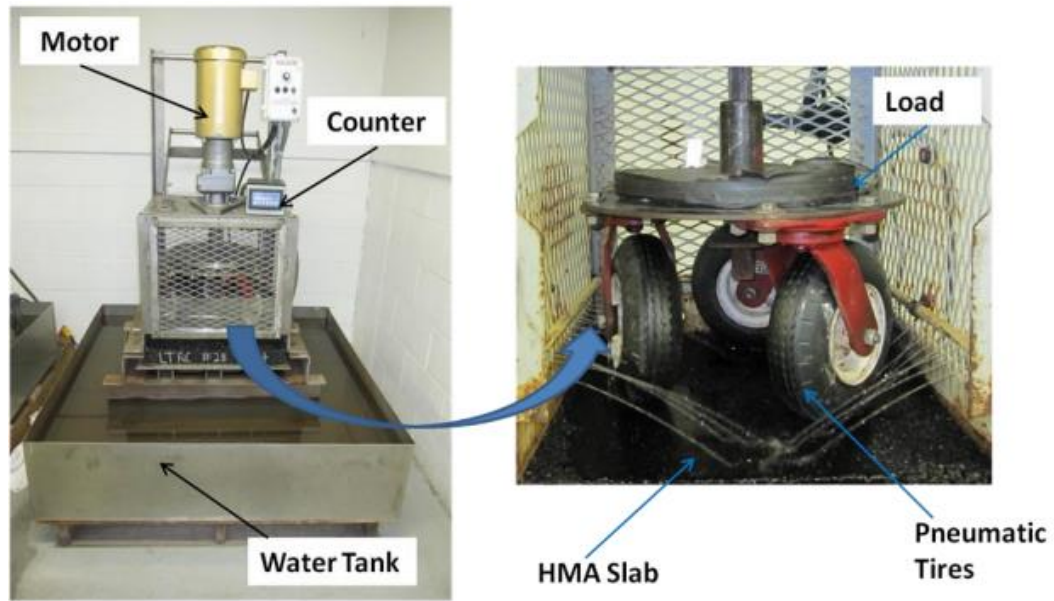

Figure 15. Three-Wheel Polishing Device (TWPD) developed by National Center for Asphalt Technology (NCAT) (Erukulla, 2011).

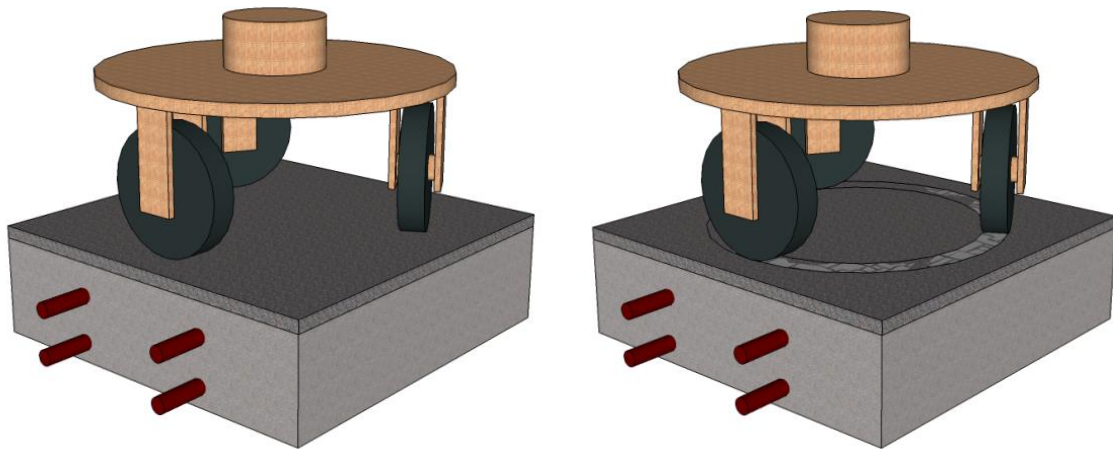

Figure 16. UWM-designed wear test device (conceptual drawing).



Figure 17. UWM-designed wear test device.

#### 4.2.4.5 Snow Plow Exposure

To simulate snow plow damage on the overlay system, a steel “snow plow” test assembly was designed. Figure 18 shows the dimensions and layout of the snow plow assembly. The total weight of this assembly was 5.0 lb. For all specimens, the snow plow test was performed at the conclusion of the Round 3 wear tests (before the last friction test). The “snow plow” assembly was attached to the wear test assembly (at the triangular aluminum plate where tires are attached) between two tires (Figures 18 and 19). The tip of







Figure 19. "Snow plow" assembly installed between two tires.

## 4.2.5 Tests and Measurements

### 4.2.5.1 Friction Measurements

There are a number of methods available for friction testing on pavement surfaces. Friction testing is typically conducted in the field using the skid test device (ASTM E 274). However, that type of testing cannot be used in the laboratory. Other options include the Dynamic Friction Tester (ASTM E 1911), the British Pendulum Tester (BPT, ASTM E303) or the NIST Brungraber Mark II tester. The BPT (Figure 20) is suitable for both field and laboratory testing. This test involves raising a pendulum to a fixed height and releasing it. The pendulum head would touch (scrape) the top surface of the specimen as it swings. The height that the pendulum rises on the opposite side indicates friction (marked numbers on the back plate are read). This test was performed on all specimens before start of exposure tests. However, BPT was deemed impractical for use in the wear test machine since the pendulum head cannot stay within the circular tire track.



Figure 20. British Pendulum Tester used on specimens prior to exposure tests.

A special friction measurement system was therefore designed for the UWM wear test machine. This design was inspired by the skid trailer test in which the wheels of the trailer are locked at highway speed, and the resulting skid force is measured. A rubber wheel attached to an aluminum frame was used for this purpose (Figure 21). An electronic locking system was used to temporarily lock the rubber wheel. A magneto-resistive break, along with a rotary encoder, was used to slow the friction wheel to the point of slipping. This would generate an instantaneous torque, which was measured with a load cell located at a known moment arm on the machine head. For friction testing at the beginning of first round (Round 0) and the end of each of the three rounds, one of the tires were removed and replaced with the rubber wheel friction assembly. The machine was allowed to spin, and then a button was pushed to temporarily lock the rubber wheel. The force generated was recorded and analyzed. Multiple readings (typically 15) were taken as the rubber wheel moved around the slab.

Figure 22 shows a typical sensor output. The change in sensor output relative to the baseline was recorded for each peak and averaged to determine the friction force. To determine the baseline value just prior to the peak, digital filters were used to smooth the baseline, and determine the average baseline value.

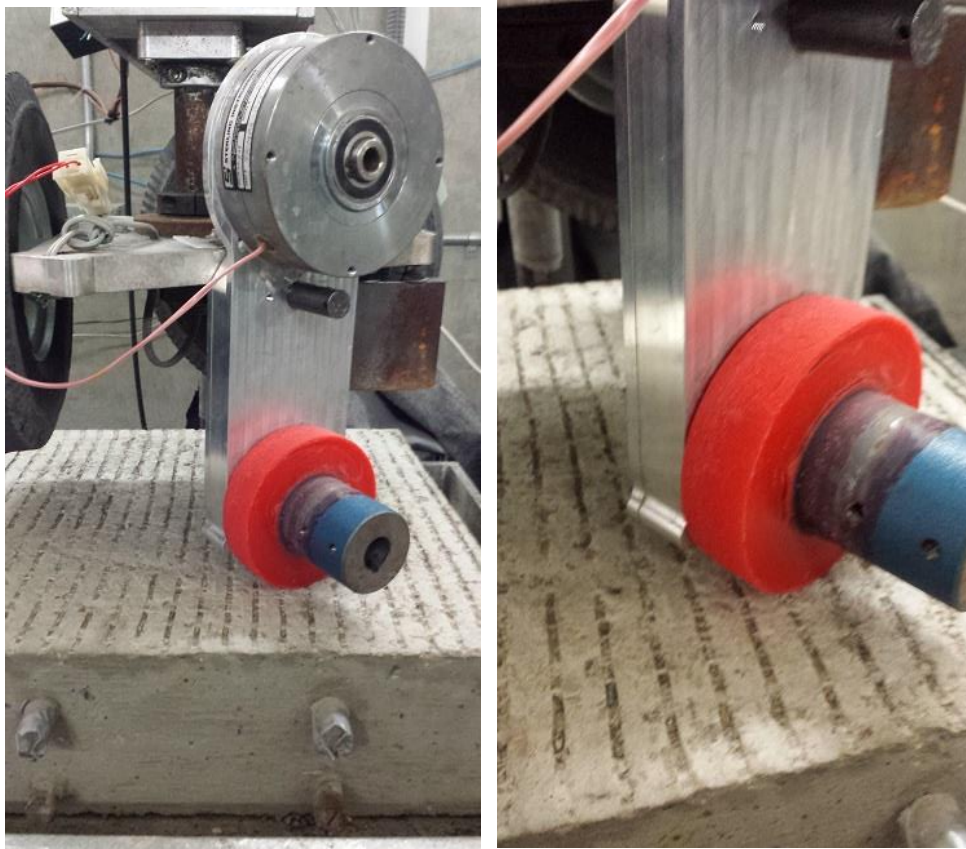

Figure 21. Friction measuring system for the UWM wear test machine.

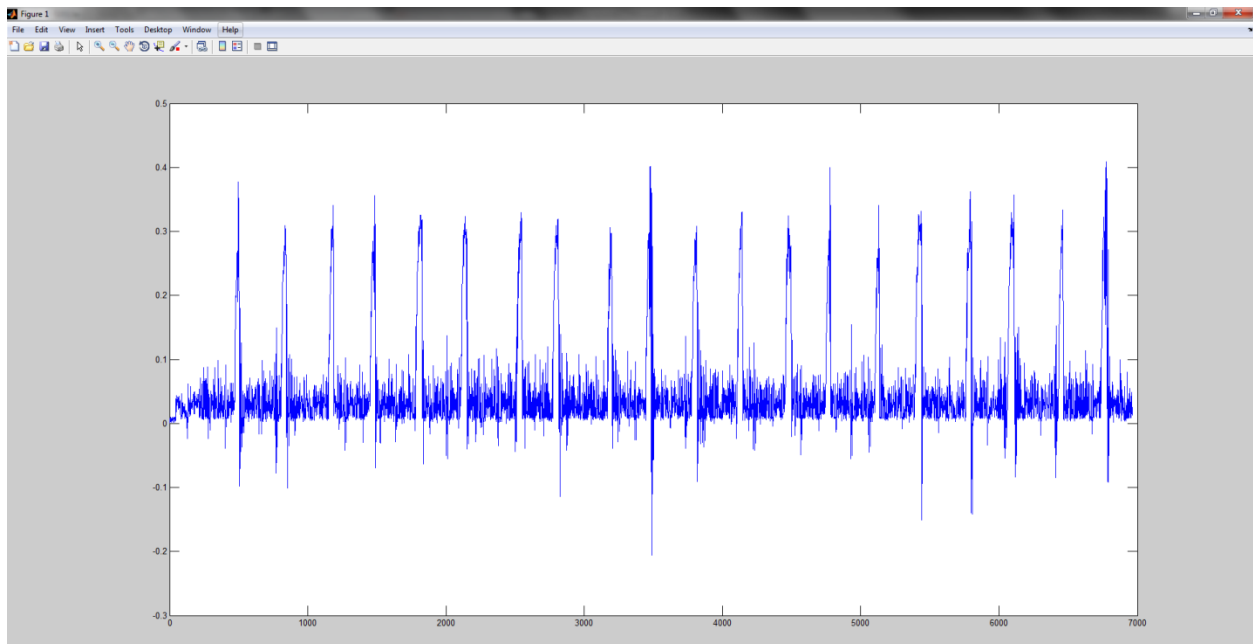

Figure 22. Typical friction sensor output.

To relate sensor output to a friction coefficient, a number of static tests were performed. A spring scale was used to apply different amounts of horizontal force to the rubber wheel, and the resulting force sensor outputs were recorded. There was a linear relationship between the magnitude of applied horizontal force and the sensor output. The magnitude of the horizontal force was divided by the weight of the machine head (114 lbs.) to arrive at the friction coefficient. A linear equation relating the friction coefficient to sensor output was therefore developed. This relationship was used to determine friction coefficients during all such tests.

#### **4.2.5.2 Coring and Pull-Out Test**

In addition to the specimens built for the exposure tests described above, one extra specimen was also build for each treatment type to measure initial bond pull-out strength. Furthermore, at the conclusion of all exposure tests, bond pull-out tests were performed on all specimens prior to dissection. The positions of the three coring locations were identical using a cardboard template for the tests at the conclusion of exposure tests. The template was not used for the initial coring prior to exposure tests. Bond pull-out tests were performed in accordance with the ACI 503 (Appendix A) procedures. First, a coring rig and a 2-in-diameter coring bit was used to cut cores into the overlay to a depth bellow the interface between the overlay and the concrete surface. The following coring procedures were used (Figures 23 and 24):

- The coring apparatus was secured on a flat solid base for the drilling operation.
- The specimen to be cored was placed on the ground next to the base of the coring machine. A cardboard template was used to mark the drilling locations on the surface of the specimen.
- The coring machine was placed over one of the three holes on the template.
- A continuous water supply was provided for the cooling of the bit during drilling.
- The coring rig was turned on and lowered to the surface.
- Coring was done at a pace of about  $\frac{1}{4}$  in every minute. Coring was done to a depth of approximately 1  $\frac{1}{2}$  in. from the surface.
- This process was repeated for the second and third cuts.



Figure 23. Coring drill setup.

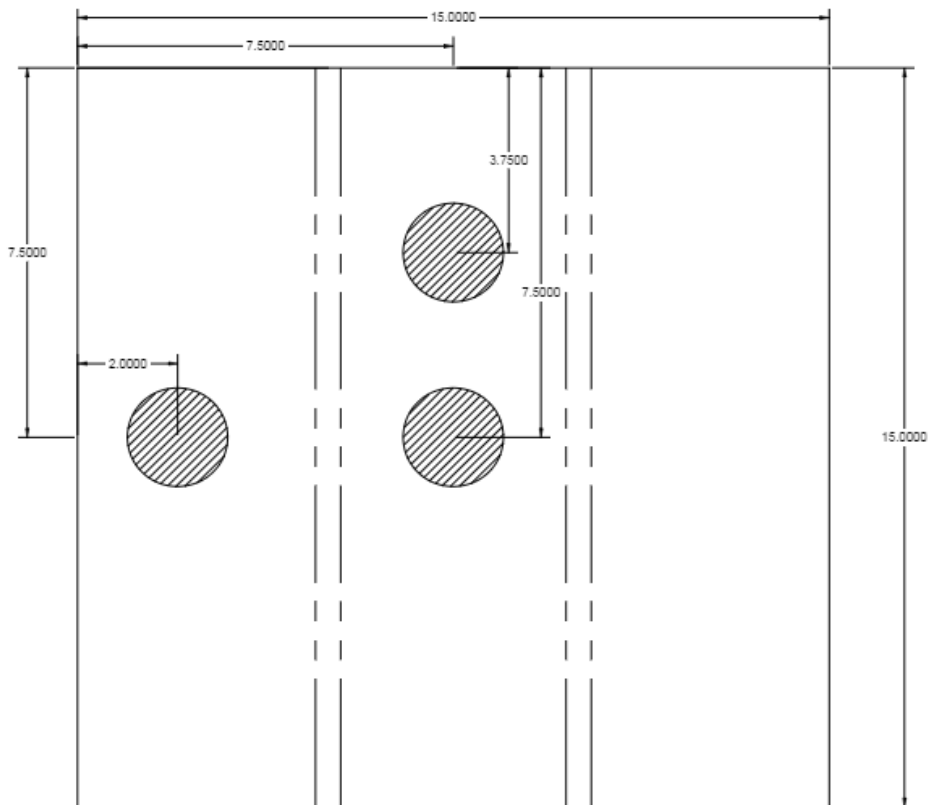

Figure 24. Schematic layout of sample coring locations after the end of exposure tests.

A digital pull-out test machine was used to measure the pull-out strength. A metal disc was attached (using epoxy adhesive) to the top surface of the cored section (Figure 25). The 2-in steel discs were custom-made with a machined 11-mm threaded portion in the center for better bond to the pull-out apparatus. Four ¼” diameter holes were drilled through the thickness of the disc to allow pouring of additional epoxy into the interface zone.



Figure 25. Pull-out test device.

The pull-out test machine was then attached to the metal disk, and the disk was pulled until failure occurred. If the failure occurred in the test hardware or the aggregates, the result of that test was not included in the data analysis. If the failure occurred in the concrete, this would indicate that the bond at the interface was higher than the tensile strength of concrete. The test results and conditions were recorded and analyzed. The procedures for the pull-out tests are summarized below:

- Using a 2-part epoxy, the steel discs were glued to the top surface of the core. Sufficient epoxy is needed to provide a complete connection.
- The epoxy was allowed to set for 48 hours. This length of time may not be necessary, but was done in this case.
- The pull-out rod was then attached to the disk, and the force gage on the device was set to zero.
- Tension was applied with the gage in the record mode.
- Once a failure occurred, the maximum force and the mode of failure was recorded.

#### 4.2.5.3 Measurement of Surface Deformation (Rut) Due to Wear

Once all the exposure tests were completed, the surface profile of the specimen was measured to assess the relative depth of the groove (rut) created as a result of the wear test and the “snow plow” passage. This measurement was performed at the end of Round 3 tests. This was accomplished by taking measurements at preset locations along the surface of each specimen. A wooden template with pre-drilled holes was used to have consistent measurement points between specimens. Twelve measurement points were spread outside of the tire track, and twelve points were located along the centerline of the tire track. At each point, the depth was measured with respect to a central baseline. The two highest and the two lowest measured values in each group were removed from analyses to eliminate localized extreme values. The averages and standard deviations of the remaining eight data point were calculated. The average depth within the center of the tire track or groove (rutted area) was subtracted from the average depth of the surrounding areas.



Figure 26. Measurement of the depth of surface groove (rut) through a dial gage at measurement points defined using a wooden template.

#### 4.2.5.4 Dissection of Specimens and Measurement of Reinforcing Bar Corrosion

After the pull-out tests were completed, all top reinforcing bars (anode or corroding bars) within all specimens were removed to measure the amount of surface corrosion. This was done by breaking the

specimens using an air hammer, removing the two top bars, cleaning the bar by grit blasting in a blasting cabinet, and then weighing and measuring them against a baseline (non-corroded and grit-blasted bars of the same size) to measure mass losses due to corrosion. The following procedures were used:

- Once the top reinforcing bars (the anodes) were removed, they were cleaned of all concrete and rust residue. The two ends of each bar that were protruding beyond the specimen (and contained the drilled connection hole) were cut off with a saw. The resulting bars had an approximate length of 15 in. The actual length was measured with a micrometer.
- The bars were cleaned by grit-blasting in a blasting cabinet.
- The weight and length of the cleaned bars were then measured. The weight was then compared against the weight of an un-corroded bar of the same size and length that was also grit-blasted (mill scale removed). Lengths of un-corroded bars were grit blasted and their lengths and weights measured to come up with an un-corroded weight per unit length. This number was then multiplied by the lengths of corroded bars and subtracted from the mass of corroded bars to arrive at the corrosion mass loss.

### **4.3 Field Testing**

The research team was informed by the Wisconsin DOT that four test segments containing four thin polymer overlay systems was being installed on a ramp (I-794 WB to I-43/I-94 SB) on the Marquette Interchange in downtown Milwaukee, Wisconsin. Each test segment was approximately 1000 square yards. The concrete deck slab on this ramp exhibited closely spaced transverse cracking (Figure 27). This structure has a twin steel box girder superstructure as shown in Figure 28.

Just prior to the installation of overlays in the summer of 2013, the research team inspected the ramp, and made surface friction measurements at various locations along the traveling lanes and the shoulders. The British Pendulum Tester (BPT) method was used (Figure 29). The research team periodically observed the surface preparations and overlay installations. Shot blasting and subsequent cleaning was used to prepare the surface before the installation of the overlays. For the 2-lift overlay systems, the resin was spread over the area (typically with a squeegee) and the aggregate was broadcast on the resin (Figure 30). The extra aggregates were removed after the resin was set. This process was then repeated for the second lift. Figure 31 shows the ramp after the installation of overlays.

Figure 32 shows a drawing of the ramp identifying the four test sections. Drawings of the individual test sections are given in Figures 33 through 36. After all installations were complete, the research team made initial BPT friction test measurements in all four sections.



Various overlay test sections were identified by WisDOT as follows (Table 10):

Table 10. Description of polymer overlay types used on Marquette Interchange ramp.

Segment	Thin Polymer Overlay type
A	<u>High Molecular Weight Methacrylate Healer/Sealer overlay</u> This section had a 1-lift high molecular weight methacrylate (HMWM) resin system with broadcast aggregates.
B	<u>Epoxy-urethane polymer overlay</u> This section had a 2-lift epoxy-urethane (co-polymer) system with aggregate and a minimum thickness of 3/8 in.
C	<u>Polyester Multi-Lift overlay</u> This section had a 2-lift polyester (2-part) overlay system with broadcast aggregates and a minimum thickness of 3/8 in.
D	<u>Polyester Premix concrete overlay</u> This section had a premixed (minimum ¾ in. thick) polyester overlay a polyester polymer concrete overlay with a HMWM resin prime coat. This overlay was placed with a screed machine.

This effort involved initial measurements of friction by the research team. It is anticipated that long-term changes in friction can be measured in the future for comparison with the initial data obtained here.

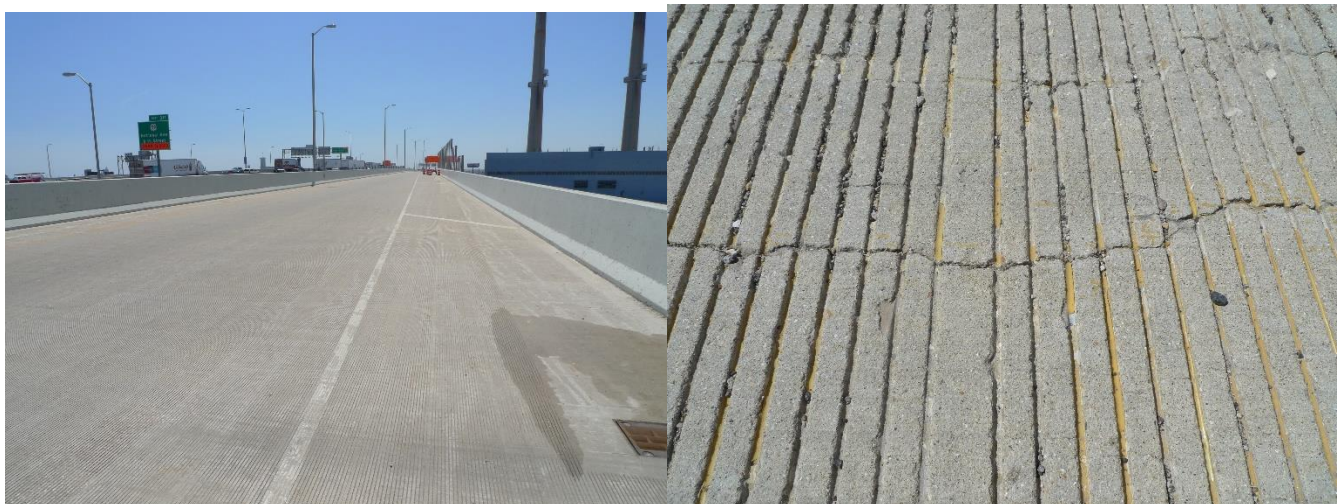

Figure 27. Marquette Interchange ramp prior to application of overlays (transverse cracking of the deck is observed).

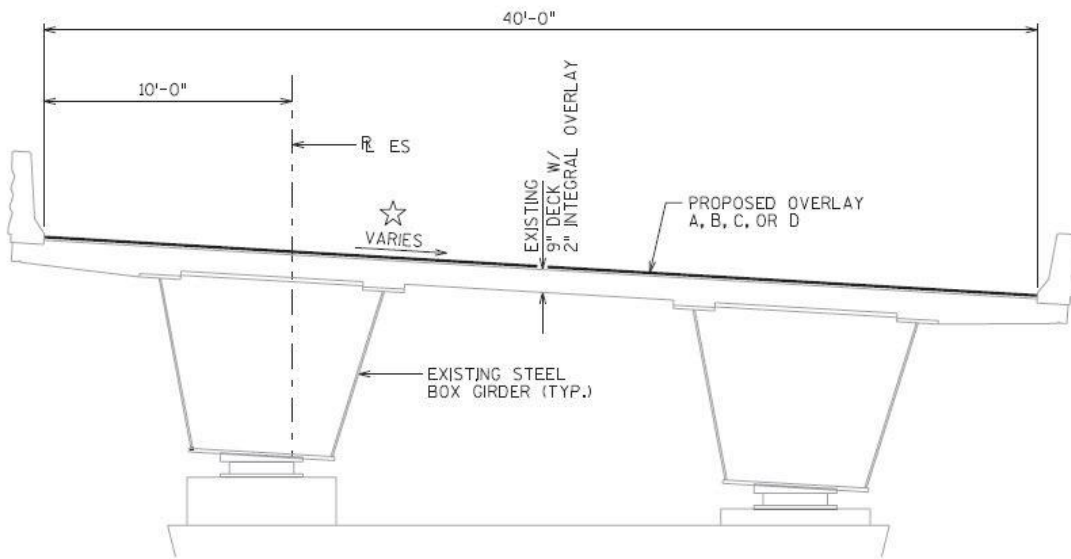

Figure 28. Cross section of Marquette Interchange ramp (from WisDOT project drawing).



Figure 29. Friction testing using BPT.



Figure 30. Placement of resin and aggregate on a 2-lift overlay system.



Figure 31. Marquette Interchange ramp after placement of four different thin polymer overlay systems (A through D).

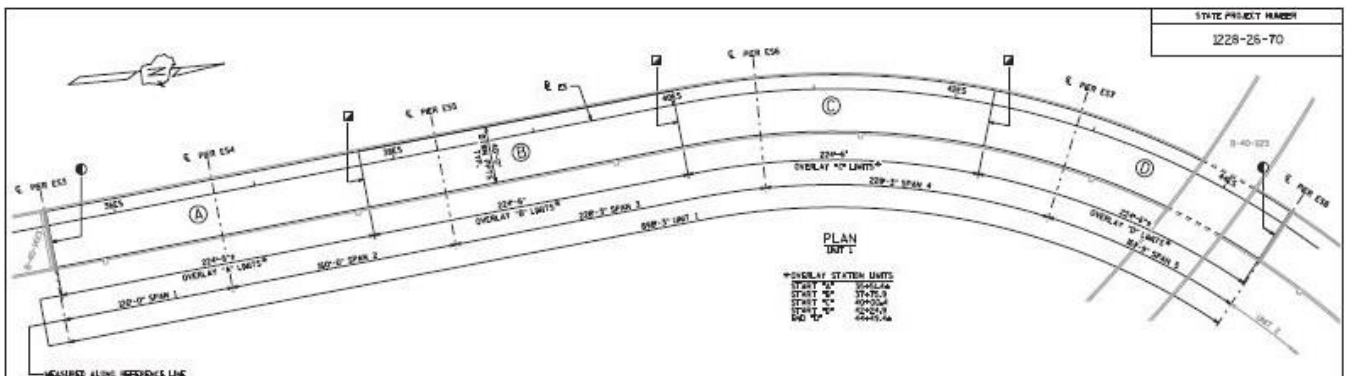

Figure 32. Four different thin polymer overlay test sections (A, B, C, and D) on the Marquette Interchange ramp (from WisDOT).

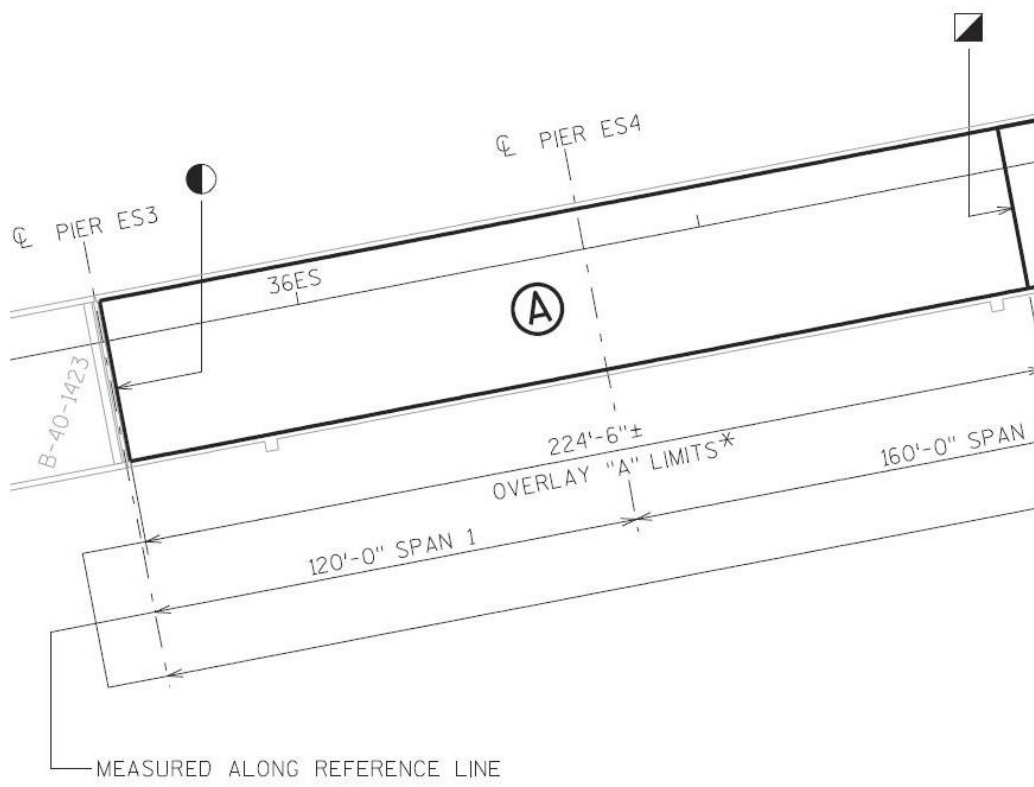

Figure 33. Section A drawing (from WisDOT).

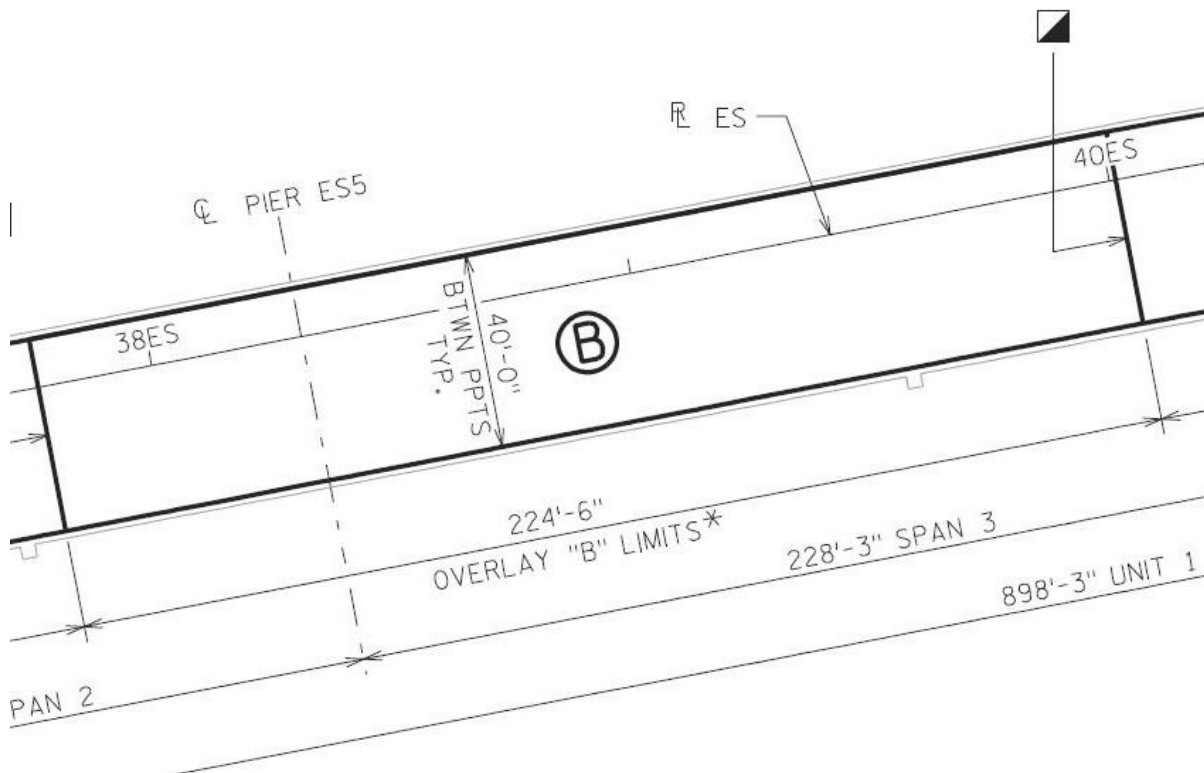

Figure 34. Section B drawing (from WisDOT).

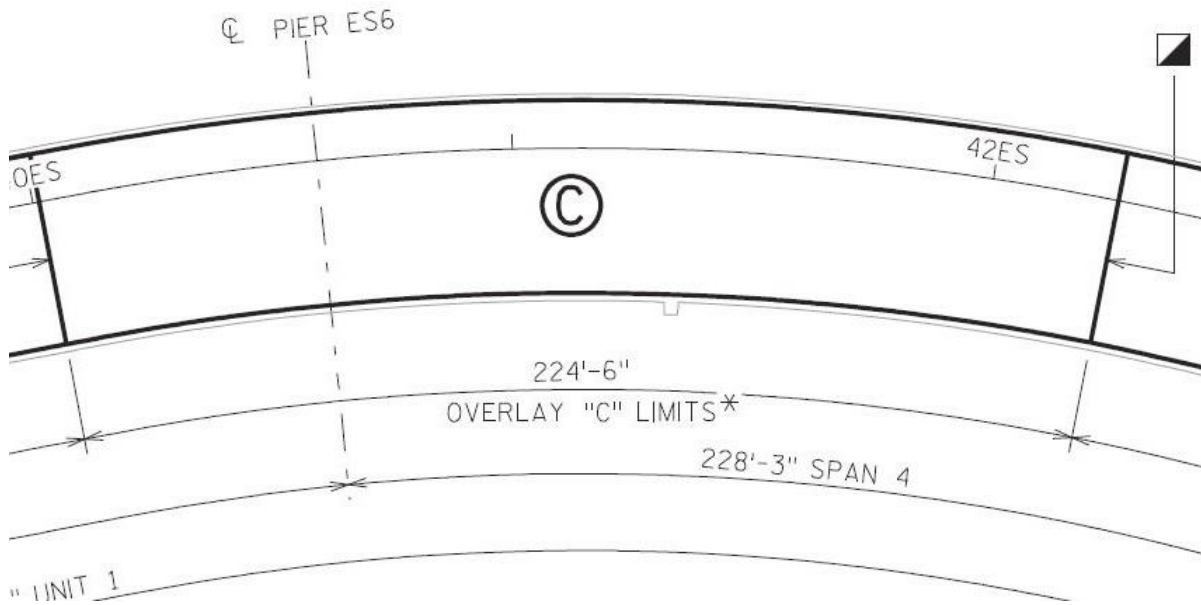

Figure 35. Section C drawing (from WisDOT).

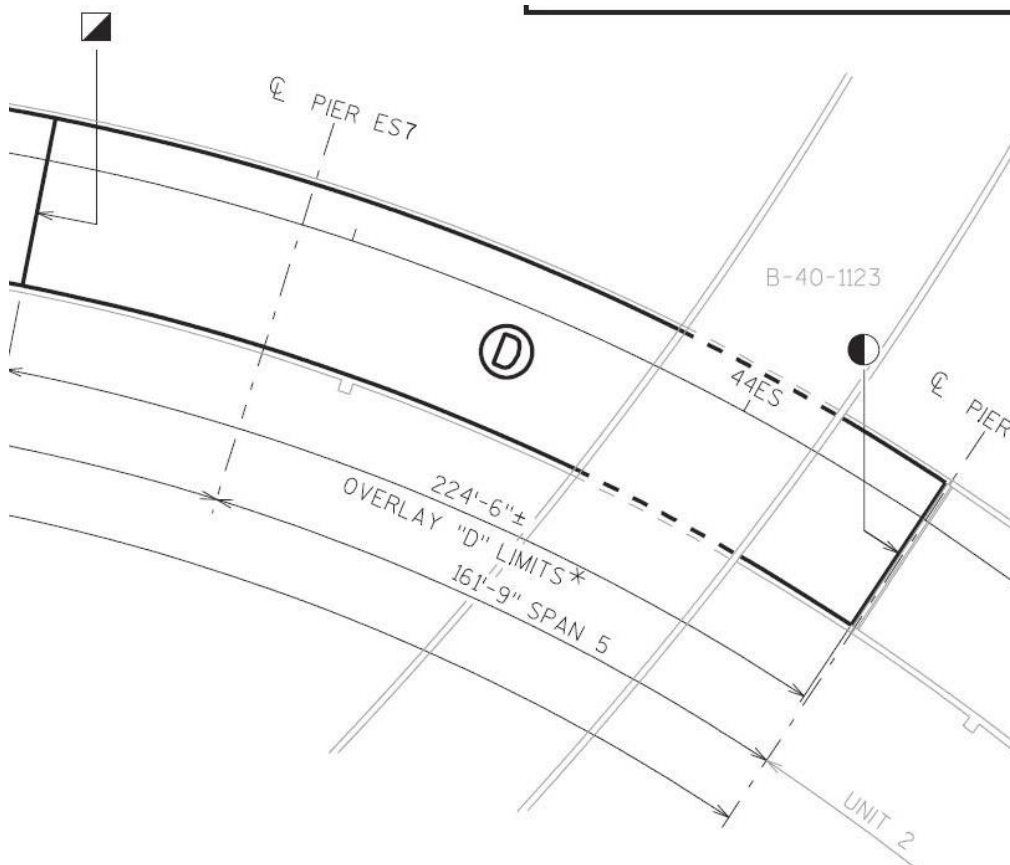

Figure 36. Section D drawing (from WisDOT).

## 5.0 EXPERIMENTAL RESULTS

In this chapter, the results of all tests involving measured parameters are presented and discussed. Data presented are from pull-out, friction, corrosion, and surface profile measurements. These results are assessed and overall evaluations are made based on development of an index system of rating.

### 5.1 Pull-Out Test Results

#### 5.1.1 Initial (baseline or Round 0) Pull-Out Strength

The results of initial pull-out tests on all overlay specimens are summarized in Table 11. These results were obtained on specimens that were not subjected to the exposure tests. Thus, these represent the baseline (Round 0) pull-out results. Average of results from at least three pull-out tests as well as the standard deviation of the results are shown. Figure 37 shows a bar chart of initial pull-out results. Error bars representing  $\pm 1$  standard deviation are shown on the graph. Results show bond strengths that are substantially higher than the typical specification acceptance limits of 250 to 300 psi. This indicates that, through careful surface preparations, high initial bond strengths were achievable by all of the overlay systems tested.

Table 11. Initial (baseline) results of pull-out tests.

Overlay Type	Average Pull-out Strength (psi)	St. dev. (psi)
S1	384.6	45.0
S2	426.4	51.5
S3	497.1	63.0
S4	513.1	21.6
S5	406.8	63.1
S6	463.6	8.1
S7	520.2	36.4
S8	431.8	84.1
S9	457.2	12.4

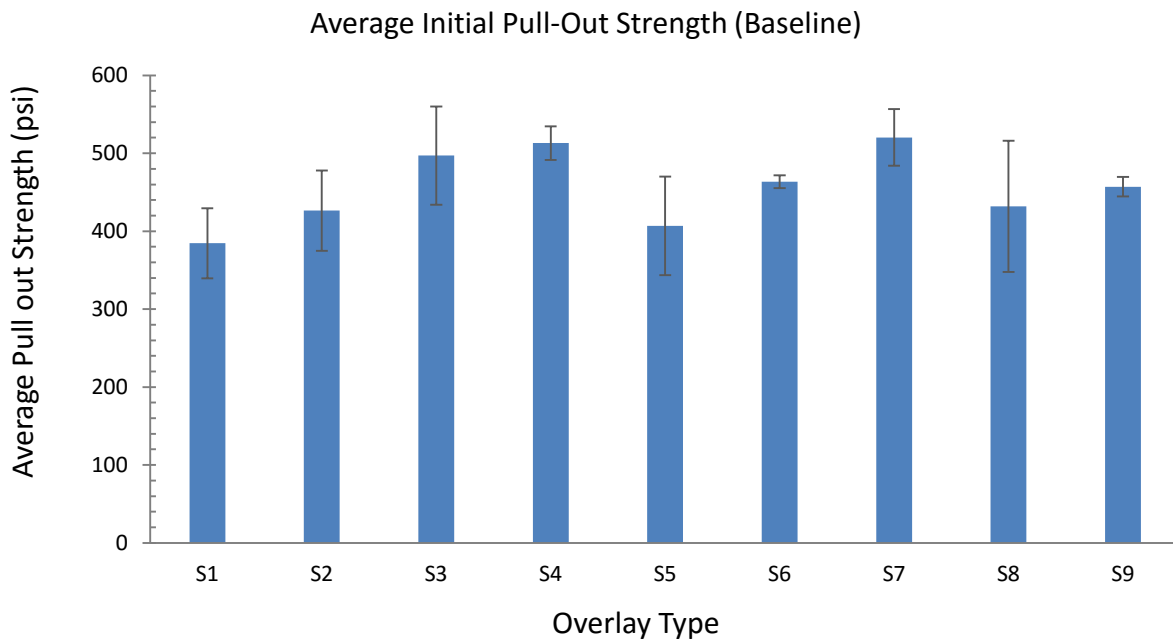

Figure 37. Average initial pull-out strength (baseline).

### 5.1.2 Final Pull-Out Strength

Table 12 and Figure 38 shows the final (Round 3) average pull-out strength results for Specimens 1 through 9. There were no pull-out results for the control specimens (S0) as an overlay was not applied on the control specimens. Error bars representing  $\pm 1$  standard deviation are shown in Figure 38 and subsequent figures.

All nine of the S8 specimens (polyester 2-lift system) had delaminated from the concrete during the exposure tests. Therefore, all the S8 pull-out strengths were at 0 psi. Figure 39 shows the top and bottom surfaces of one delaminated S8 specimen. The overlay cleanly separated from the concrete surface. Results of the field tests (discussed later) indicate that the polyester multi-lift system on the Marquette Interchange ramp segment had also delaminated at several areas after approximately two years of field service. The S8 specimen had a reasonable initial pull-out strength (432 psi) that was in line with the other overlay systems. However, for reasons that are not clear at this point, both the field and laboratory test specimens and section resulted in the delamination of the overlay.

Specimens S1 through S7 had final pull-out strength ranging from 357.5 to 434.9 psi. Specimen S9 had a lower average final pull-out strength compared to S1 through S7 specimens. But an average pull-out strength value of approximately psi would still meet pull-out specification requirements. As expected, the type of aggregate type did not have a major influence on pull-out strength.

Table 13 and Figure 40 shows final pull-out strength results for Group A, B, and C specimens. The presence of various levels of chlorides in concrete (Groups A, B, and C) had inconsistent influence on pull-out strengths across different overlay systems. Therefore, the extent of chloride contamination cannot be linked with pull-out strengths.

Table 12. Final average pull-out strength for all groups.

Specimen	Ave. Pull-out Strength of All Groups (psi)	St. dev. of All Groups (psi)
S1	422.1	41.1
S2	403.4	46.5
S3	434.9	46.2
S4	398.3	2.1
S5	418.8	29.0
S6	357.7	44.6
S7	398.2	26.8
S8	0.0	0.0
S9	295.7	88.0

Table 13. Final average pull-out strength for groups A, B, and, C.

Specimen	Avg. Pull-out Strength (Psi)	St. dev. (psi)	Specimen	Avg. Pull-out Strength (Psi)	St. dev. (psi)	Specimen	Avg. Pull-out Strength (Psi)	St. dev. (psi)
S1-A	387.1	45.0	S1-B	467.5	57.9	S1-C	411.8	73.0
S2-A	403.8	50.0	S2-B	449.7	92.6	S2-C	356.7	33.2
S3-A	458.6	52.2	S3-B	381.7	73.8	S3-C	464.6	106.9
S4-A	396.0	99.9	S4-B	398.7	37.0	S4-C	400.2	62.8
S5-A	397.4	91.4	S5-B	407.3	66.4	S5-C	451.8	92.8
S6-A	308.3	179.1	S6-B	395.0	22.2	S6-C	369.8	71.3
S7-A	380.0	52.1	S7-B	429.0	84.1	S7-C	385.7	50.8
S8-A*	0.0	0.0	S8-B*	0.0	0.0	S8-C*	0.0	0.0
S9-A	195.2	50.0	S9-B	359.6	37.9	S9-C	332.1	34.3



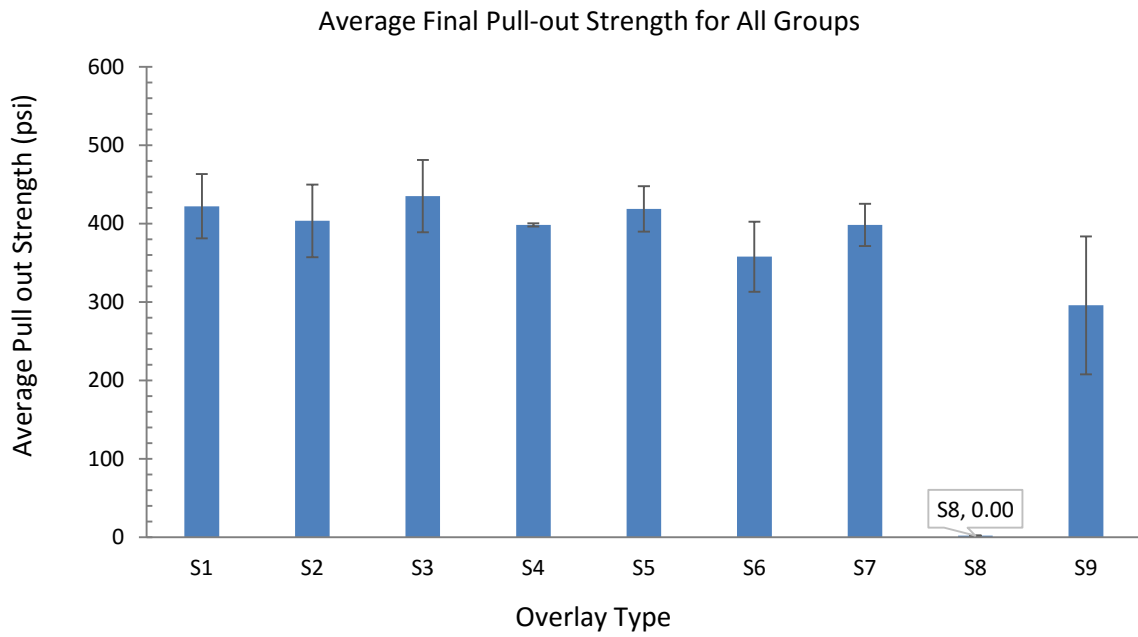

Figure 38. Average final pull-out strength of all groups.



Figure 39. Pictures of delaminated overlay from a S8 specimen: top surface (left), bottom surface (right).

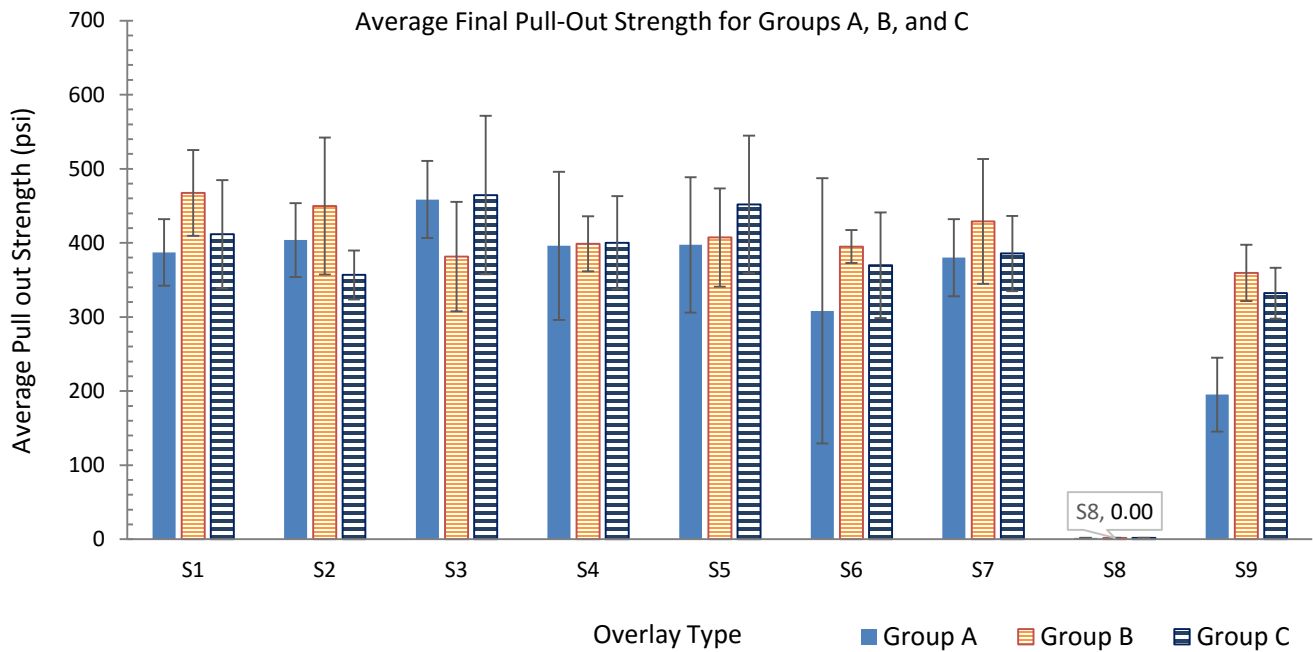

Figure 40. Average final pull-out strength for groups A, B, and C.

### 5.1.3 Discussion of Pull-Out Results

Test results clearly show that the 2-lift polyester overlay system would delaminate from the concrete surface even though its initial pull-out strength is in line with the other overlay types. Furthermore, the type of aggregate does not seem to influence the pull-out strength results significantly. Presence of higher chlorides on some specimens (Groups B and C) does not appear to have a significant influence on pull-out strengths.

## 5.2 Friction Test Results

### 5.2.1 Initial Friction Results

Table 14 and Figure 41 show the initial (baseline or Round 0) friction results. All overlay types had initial friction results (ranging from 0.701 to 0.781), which were in line with the initial friction result for the control (S0 specimen - tined concrete without overlay). The S7 and S8 overlays (polyester pre-mixed and polyester 2-lift, respectively) exhibited slightly lower initial friction compared to the control and other overlays. The S1 overlay (with flint aggregate) had slightly higher initial friction compared to S3 (calcined bauxide) and S2 (granite). At a friction coefficient of 0.781, the S1 overlay had the second highest initial friction after the S0 (control) specimens (with a friction coefficient of 0.783).

Table 14. Initial (Round 0) average coefficient of friction of all groups.

Specimen	Coefficient of Friction	St. Dev.
S1	0.781	0.102
S2	0.741	0.052
S3	0.769	0.132
S4	0.736	0.082
S5	0.764	0.051
S6	0.730	0.030
S7	0.703	0.064
S8	0.701	0.132
S9	0.744	0.065
S0	0.783	0.054

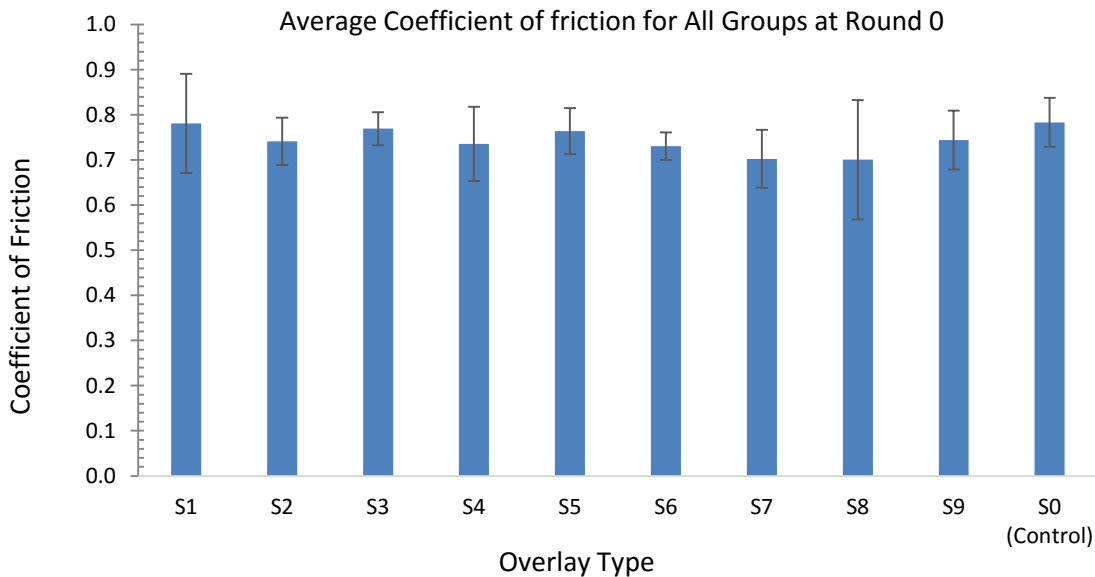

Figure 41. Initial average coefficients of friction for all groups at Round 0.

### 5.2.2 Final Friction Results

Table 15 and Figure 43 show the final (Round 3) friction values for Group A, B, and C specimens. An overall reduction in friction relative to initial results is evident. The average coefficient of friction for the control (S0) reduced from 0.783 to 0.559. All overlay friction values were lower after Round 3 testing relative to Round 0 tests. For the most part, Group A specimens show higher coefficients of friction compared to Group B and C specimens. However, Group C specimens show slightly higher friction compared to Group B. Therefore, there is no consistent trend relating initial chloride content with friction coefficients.

Figures 42-44 and Table 16 show the average friction values (averaged across all Groups A, B, and C) for Rounds 0, 1, 2, and 3. It is clear that there is a light increase in friction between Round 0 and Round 1 results for all specimen types. This may be related to early fracturing that would result in an increase in friction early in the wear test. As expected, coefficients of friction generally decreased with additional wear in all overlay types. The two highest average friction coefficients at the end of Round 3 were 0.641 for S1 and 0.639 for the S9 overlay systems. At the end of Round 3, all overlay types had higher friction coefficients compared to the S0 control (0.559). However, S3 and S7 overlays had the second (0.583) and third (0.584) lowest Round 3 frictions after S0. Among aggregate type, flint rock appears to provide the highest Round 3 friction when compared to S2 and S3 overlays that had the same epoxy resin as the S1.

Table 15. Final coefficient of friction (Round 3) values for groups A, B, and C.

Specimen	Coefficient of Friction	St. Dev.	Specimen	Coefficient of Friction	St. Dev.	Specimen	Coefficient of Friction	St. Dev.
S1-A	0.753	0.087	S1-B	0.604	0.057	S1-C	0.566	0.075
S2-A	0.684	0.098	S2-B	0.499	0.059	S2-C	0.646	0.061
S3-A	0.624	0.111	S3-B	0.550	0.052	S3-C	0.576	0.060
S4-A	0.637	0.087	S4-B	0.577	0.061	S4-C	0.601	0.055
S5-A	0.605	0.045	S5-B	0.586	0.046	S5-C	0.598	0.073
S6-A	0.674	0.056	S6-B	0.513	0.057	S6-C	0.601	0.055
S7-A	0.610	0.047	S7-B	0.526	0.059	S7-C	0.617	0.057
S8-A	0.632	0.046	S8-B	0.571	0.050	S8-C	0.611	0.069
S9-A	0.666	0.085	S9-B	0.658	0.071	S9-C	0.594	0.055
S0-A	0.559	0.042						

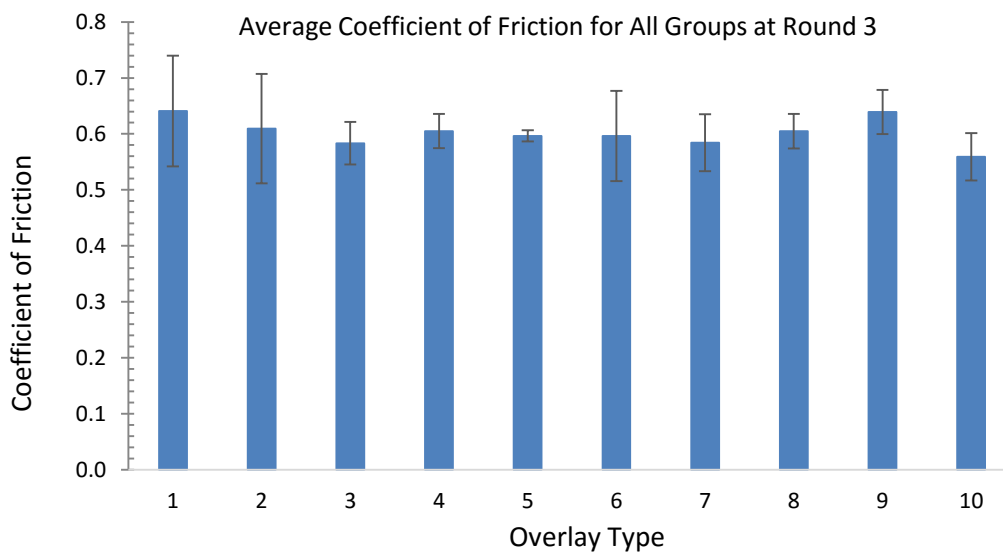

Figure 42. Average coefficient of friction for all groups at round 3.

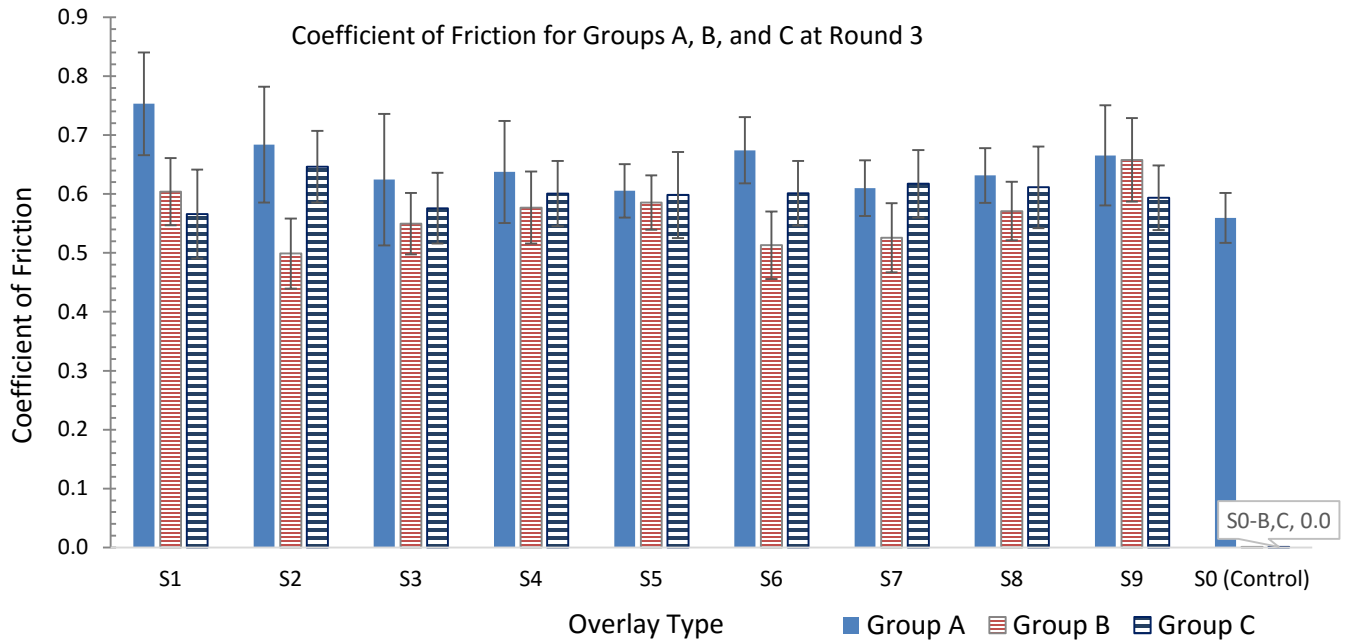

Figure 43. Coefficient of friction for groups A, B, and Cat Round 3.

Table 16. Average coefficient of friction for all groups at round 0, 1, 2, and 3.

Actual Average Coefficient of Friction											
Round #	Tire Passes	S1	S2	S3	S4	S5	S6	S7	S8	S9	S0
Round 0	0	0.781	0.741	0.769	0.736	0.764	0.730	0.703	0.701	0.744	0.783
Round 1	33000	0.809	0.789	0.801	0.760	0.787	0.783	0.710	0.785	0.728	0.759
Round 2	66000	0.652	0.632	0.586	0.622	0.608	0.635	0.590	0.624	0.606	0.602
Round 3	99000	0.641	0.610	0.583	0.605	0.596	0.596	0.584	0.605	0.639	0.559

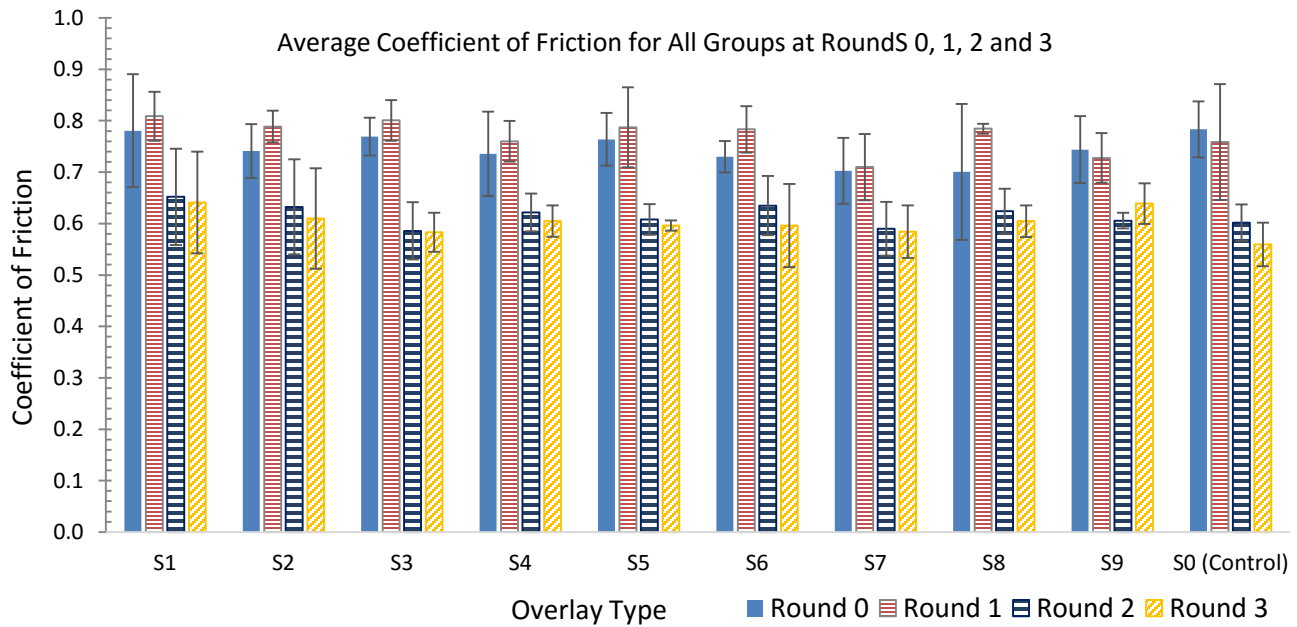

Figure 44. Average coefficient of friction for all groups at round 0, 1, 2, and 3.

To assess the trends in the reduction of the coefficients of friction, equations were fitted to Round 1, 2, and 3 friction results. A curve fitting software (CurveExpert) was used to assess different equations representing the change in friction with the number of tire passages. After a number of trials, the following equation was selected to provide a declining curve that best fits the data across most overlay systems:

$$y = ae^{b/x} \quad (\text{Eq. 1})$$

The parameters of Eq. 1 were determined using the software program. Parameters ‘a’ and ‘b’ were determined for each overlay type as well as the control specimens. The coefficients of determination ( $R^2$ ) were calculated. These parameters are shown in Table 17. It should be noted that a relationship between tire passages in the laboratory setup and the tire passages in the field is not known at this point. So, Eq. 1 results would not represent tire passages in field applications.

Figure 45 shows actual test results (discrete points) as well as projected friction values using Eq. 1 for all overlay types and controls. The highest projected overall friction values correspond to S1 and S9 overlays, and the lowest correspond to the control and S3 overlay. The difference between S1 and S3 overlays is in the type of aggregate used, as the epoxy resin was the same in both overlay types.

### 5.2.3 Discussion of Friction Results

Initial test results indicated that tined concrete surface had the highest initial friction values. However, with the exposure tests, the control specimen had the lowest friction values at the end of testing. Epoxy

resin with flint rock appears to provide the highest friction at the end of Round 3. However, friction values decrease with passage of tires.

Of the three aggregate types (flint, granite, and calcined bauxite) used with the same epoxy resin (S1, S2, S3), the flint rock resulted in the highest friction values at the end of tests, while calcined bauxite exhibited the lowest friction results. The only overlay system with the taconite aggregate (S9) provided the second highest friction values at the end of testing. However, a direct comparison of other aggregates with taconite could not be made since there were no tested overlay systems with the same epoxy and taconite.

Table 17. Parameters for Modified Exponential Fit-Curve.

Overlay Types	Modified Exponential Coefficient		
	a	b	R <sup>2</sup>
S1	0.554	1.23E+04	0.974
S2	0.525	1.33E+04	0.990
S3	0.471	1.73E+04	0.961
S4	0.529	1.19E+04	0.985
S5	0.500	1.48E+04	0.974
S6	0.518	1.36E+04	0.999
S7	0.516	1.04E+04	0.966
S8	0.518	1.36E+04	0.986
S9	0.566	7.97E+03	0.774
S0	0.479	1.52E+04	0.999

### 5.3 Corrosion Test Results

#### 5.3.1 Final Corrosion Results

Tables 18 and 19 show average corrosion mass losses (in percent) and their corresponding standard deviations for all overlay types and specimen groups at the end of testing. Overall, the epoxy-based overlays S1 through S3 as well as the S7 overlay (polyester pre-mixed) provided the lowest corrosion mass loss across all specimens' groups. These mass losses were less than the S0 (control) mass losses in Group A specimens. However, on average, the Group A overlay specimens had only 7% less mass loss compared to the control specimens. As expected, Group C specimens had the highest corrosion mass losses compared to Groups A and B for each overlay type. The highest overall corrosion mass losses were associated with S8, S4, S5 and S6 overlays (Figure 46). The addition of overlays to previously chloride-contaminated concrete (Groups B and C) does not appear to significantly reduce corrosion mass loss during the duration of testing (Figure 47). However, the epoxy-based overlays under the Group B category

have similar mass losses compared to the control. Therefore, the limit of potential application of overlays (S1 through S3) for any beneficial corrosion results corresponds to a Group B chloride content.

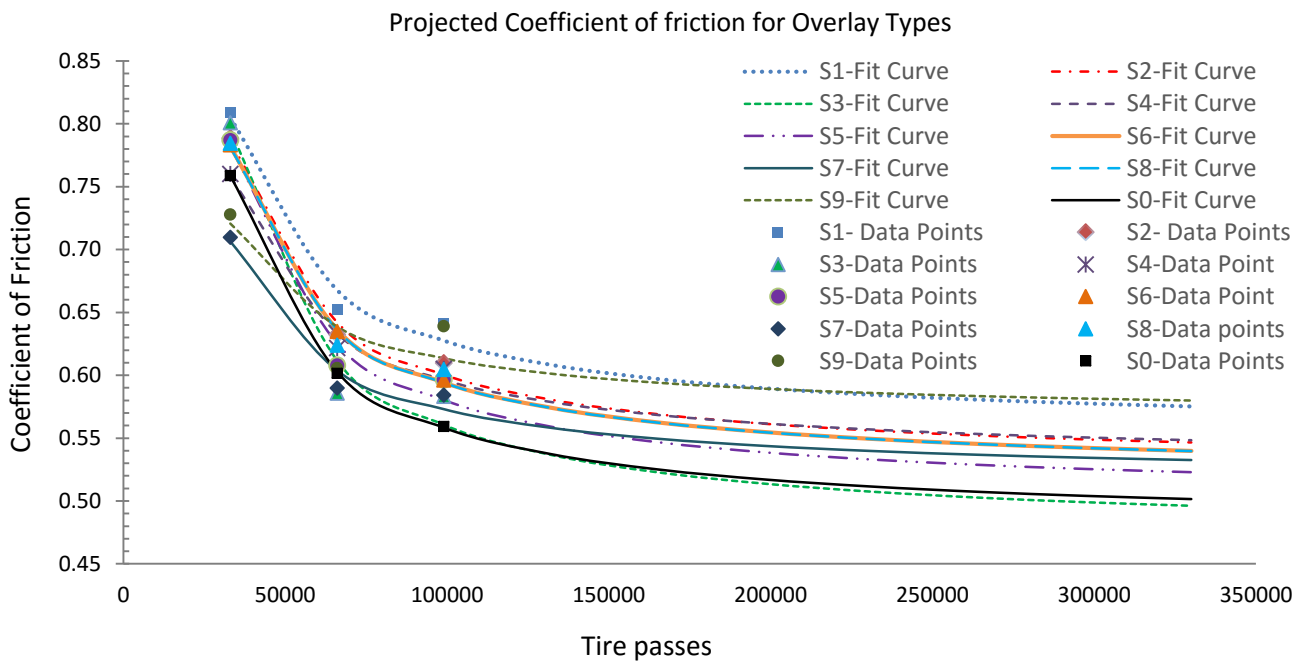

Figure 45. Projected coefficients of friction for various overlay types.

Table 18. Average corrosion mass losses and standard deviations for Groups A, B, and C.

Average % Mass Loss by Specimen Group								
Specimen	% Change	St. Dev. %	Specimen	% Change	St. Dev. %	Specimen	% Change	St. Dev. %
S1-A	-2.08	0.36	S1-B	-3.14	0.55	S1-C	-3.67	1.65
S2-A	-2.87	0.42	S2-B	-2.79	0.57	S2-C	-3.52	1.19
S3-A	-2.29	0.54	S3-B	-2.95	0.13	S3-C	-2.97	0.50
S4-A	-2.81	0.45	S4-B	-5.25	0.68	S4-C	-3.04	0.45
S5-A	-2.86	0.05	S5-B	-3.28	0.39	S5-C	-5.09	0.76
S6-A	-2.78	0.27	S6-B	-3.59	0.61	S6-C	-4.32	0.90
S7-A	-2.37	0.94	S7-B	-3.32	1.24	S7-C	-3.26	0.33
S8-A	-3.69	0.64	S8-B	-3.64	0.30	S8-C	-4.20	0.74
S9-A	-2.29	0.48	S9-B	-3.70	0.73	S9-C	-3.17	1.16
S0-A	-2.8745	0.3130						



Table 19. Average corrosion mass losses and standard deviations for all specimen groups.

Average % Change for all Specimens Groups		
Specimen	All. Groups	St. Dev. %
S1	-2.96	0.81
S2	-3.06	0.40
S3	-2.74	0.39
S4	-3.70	1.35
S5	-3.74	1.19
S6	-3.56	0.77
S7	-2.99	0.53
S8	-3.84	0.31
S9	-3.05	0.71
S0 (Control)	-2.87	0.00

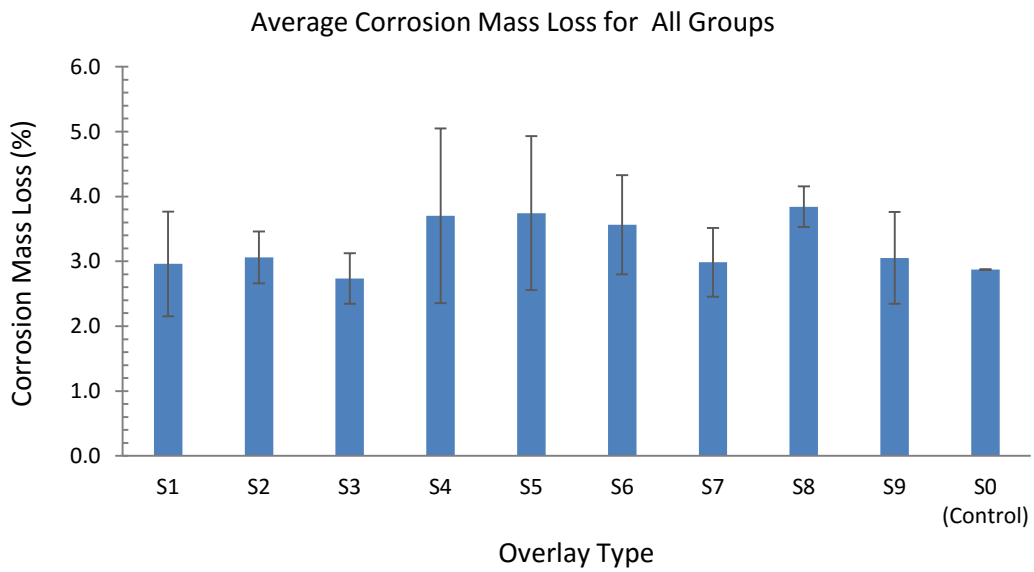

Figure 46. Average corrosion mass loss for all groups.

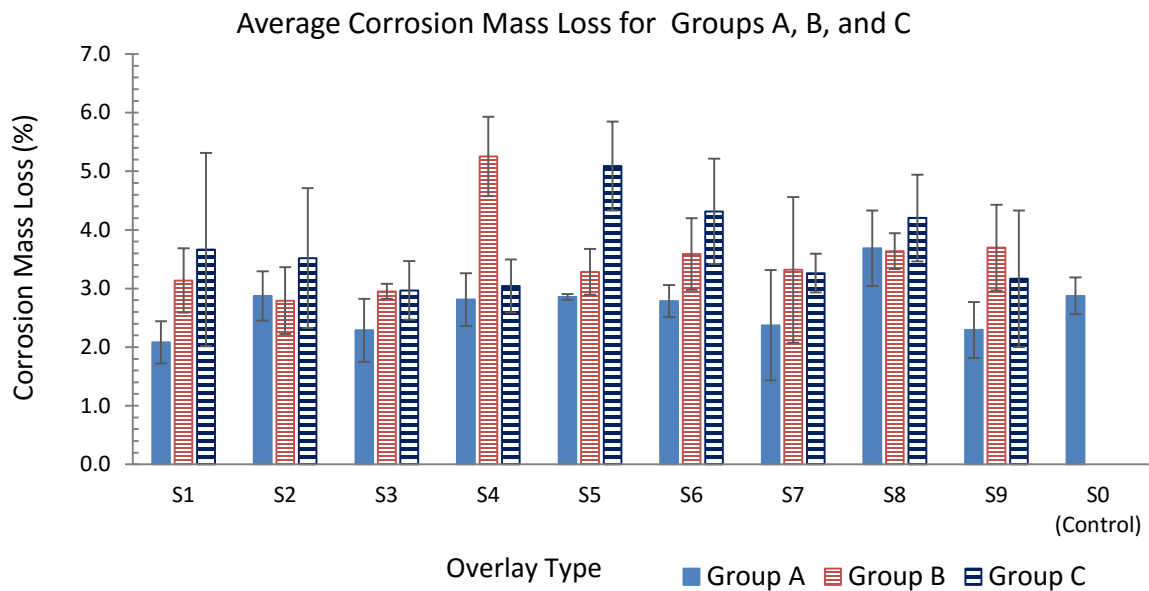

Figure 47. Average corrosion mass loss for Groups A, B, and C.

### 5.3.3 Discussion of Corrosion Results

Three epoxy-based overlays (S1, S2, and S3) and the polyester premix (S7) offer reduced corrosion losses compared to the controls in Group A specimens. The average losses across all three specimen groups were smallest for the epoxy overlay groups (S1, S2, and S3) and the polyester premix overlay (S7). However, the addition of overlays does not significantly reduce corrosion mass loss in Group B and C specimens. In fact, mass losses in groups B and C are substantially higher than in Group A specimens. Therefore, the placement of a thin-polymer overlay on a chloride contaminated bridge deck undergoing corrosion of the embedded steel cannot be considered to be a corrosion mitigation strategy. Such a step (application of overlay) may still be taken for other reasons such as improving friction or providing a smooth riding surface over a limited time period. However, the overlay must be installed on sound concrete under all circumstances, and it must be realized that the overlay will eventually fail due to corrosion of the underlying reinforcement, if not for other factors.

## 5.4 Surface Profile Results

### 5.4.1 Final Surface Profile Results

The average surface deformations along the tire track (relative to areas outside the tire tracks) for all specimens (rut depths) are shown in Table 20. The average rut depth across all specimen groups (Groups A, B, and C) are shown in Table 21. The standard deviations of the results are relatively large because of

the variation in surface profiles due to presence of aggregates. However, several trends are evident. The highest overall deformations correspond to S4, S8, and S9 overlays. All specimens with overlays have average rut depths that are higher than the corresponding deformation for the control specimens (Figure 48). As expected, there is no clear pattern related to the specimen groups A, B, and C (Figure 49).

Table 20. Average surface deformations for groups A, B, and C.

<b>Surface profile Average for Group A, B, and C</b>								
Specimen	Avg. Rut Depth (in)	St. Dev. (in)	Specimen	Avg. Rut Depth (in)	St. Dev. (in)	Specimen	Avg. Rut Depth (in)	St. Dev. (in)
<b>S1-A</b>	0.052	0.032	<b>S1-B</b>	0.042	0.003	<b>S1-C</b>	0.057	0.022
<b>S2-A</b>	0.040	0.022	<b>S2-B</b>	0.051	0.008	<b>S2-C</b>	0.043	0.008
<b>S3-A</b>	0.031	0.010	<b>S3-B</b>	0.050	0.009	<b>S3-C</b>	0.035	0.007
<b>S4-A</b>	0.066	0.018	<b>S4-B</b>	0.114	0.013	<b>S4-C</b>	0.073	0.004
<b>S5-A</b>	0.020	0.018	<b>S5-B</b>	0.072	0.036	<b>S5-C</b>	0.043	0.012
<b>S6-A</b>	0.056	0.036	<b>S6-B</b>	0.050	0.012	<b>S6-C</b>	0.045	0.035
<b>S7-A</b>	0.036	0.022	<b>S7-B</b>	0.036	0.014	<b>S7-C</b>	0.042	0.022
<b>S8-A</b>	0.046	0.039	<b>S8-B</b>	0.090	0.014	<b>S8-C</b>	0.099	0.013
<b>S9-A</b>	0.054	0.020	<b>S9-B</b>	0.060	0.011	<b>S9-C</b>	0.061	0.018
<b>S0-A</b>	0.015	0.006						

Table 21. Average surface deformations of all groups.

<b>Surface profile Average for All Groups</b>		
Specimen	Total Avg. Rut Depth (in)	St. Dev. (in)
<b>S1</b>	0.050	0.008
<b>S2</b>	0.045	0.006
<b>S3</b>	0.039	0.010
<b>S4</b>	0.084	0.026
<b>S5</b>	0.045	0.026
<b>S6</b>	0.050	0.006
<b>S7</b>	0.038	0.003
<b>S8</b>	0.079	0.041
<b>S9</b>	0.058	0.004
<b>S0 (Control)</b>	0.015	0.006

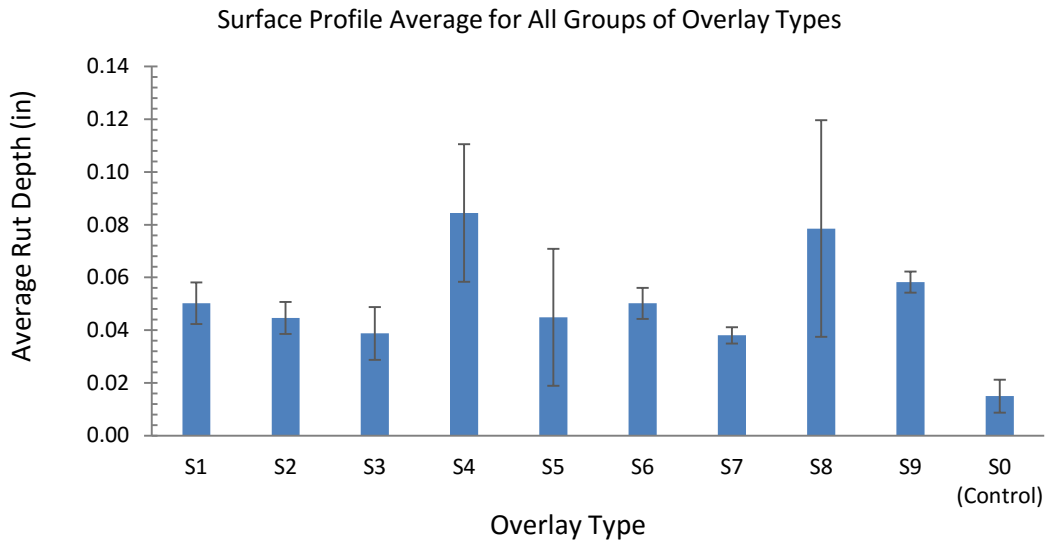

Figure 48. Surface profile average for all groups of overlay types.

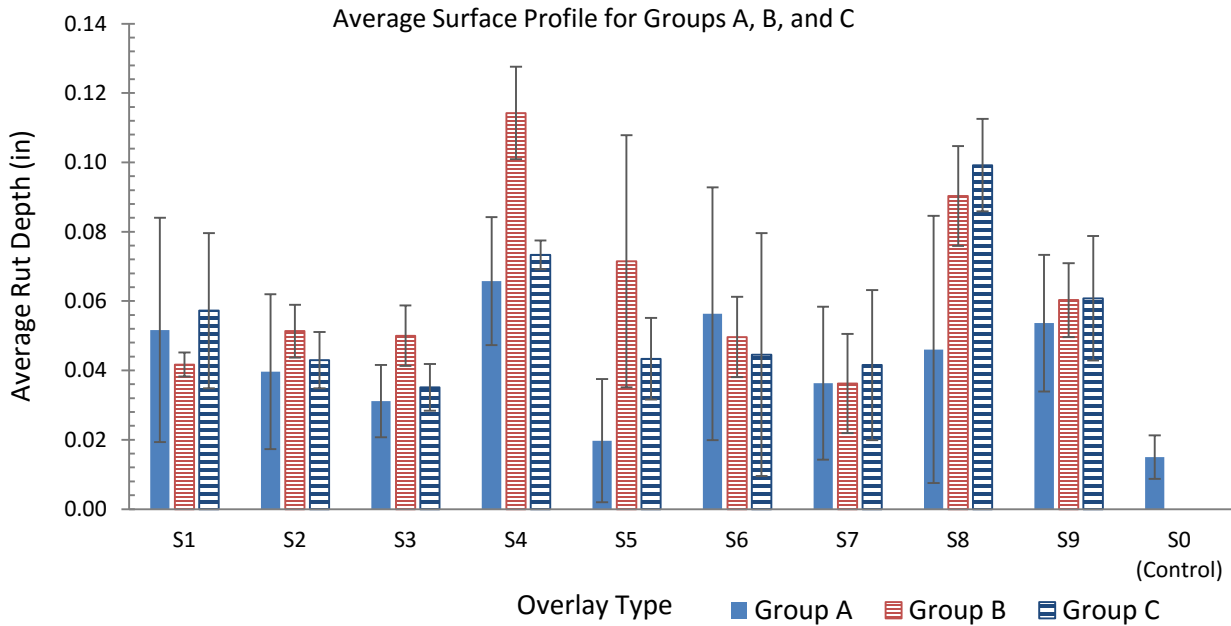

Figure 49. Average surface profile for groups A, B, and C.

#### 5.4.2 Discussion of Surface Profile Results

The application of thin polymer overlay results in surface deformations along the tire tracks that are deeper than the concrete surface itself. Specimens S4, S8, and S6 had the highest relative surface deformation.

Such surface deformation may or may not be a concern relative to the other parameters of interest discussed above.

## **5.5 Overall Analysis of Laboratory Results**

### **5.5.1 Indexed Final Results**

Four sets of parameters were measured at the conclusion of testing. These were the pull-out strength, friction coefficient, corrosion mass loss, and surface deformation. To compare the results in a non-dimensional form, an index system was devised. A numerical index was given to each overlay type for each of the measurement parameters. First, the mean Round 3 values ( $\mu$ ) of a parameter (say friction) was calculated for all overlay types (S1 through S9). The corresponding standard deviation was also calculated ( $\sigma$ ). The index was calculated using the following equation:

$$I = \left( \frac{x-\mu}{\sigma} \right) \quad (\text{Eq. 2})$$

Where I is the index for a particular parameter, and x is the average value of that parameter for each overlay type. To associate higher indices with better performance, a negative sign was added in front of Eq. 2 when calculating corrosion mass loss and surface profile indices. The index for control (S0) was calculated using Eq. 2. However, the mean and standard deviation values are for the nine overlay types.

Table 22 shows the calculated indices for the pull-out strength. The highest pull-out index belonged to S3 while the lowest index was associated with S8. The highest and lowest indices for friction corresponded to S1 and S7, respectively. The highest (best) and lowest (worst) corrosion mass loss indices corresponded to S1 and S8, respectively. Finally, the surface profile index was highest (best) for S3, and lowest (worst) for S4.

Table 22. Index values for pull-out strength.

<b>Pull-Out Test</b>		
<b>Specimen</b>	<b>Average All Groups (psi)</b>	<b>Index</b>
<b>S1</b>	422.13	0.5
<b>S2</b>	403.39	0.4
<b>S3</b>	434.94	0.6
<b>S4</b>	398.30	0.4
<b>S5</b>	418.82	0.5
<b>S6</b>	357.68	0.1
<b>S7</b>	398.23	0.4
<b>S8</b>	2.00	-2.5
<b>S9</b>	295.65	-0.4
<b>Mean (S1-S9) (<math>\mu</math>)</b>	347.90	
<b>St. Dev. (S1-S9) (<math>\sigma</math>)</b>	136.35	

Table 23. Index values for coefficient of friction results.

<b>Coefficient of Friction</b>		
<b>Specimen</b>	<b>Average All Groups (Round 3)</b>	<b>Index</b>
<b>S1</b>	0.641	1.6
<b>S2</b>	0.610	0.1
<b>S3</b>	0.583	-1.1
<b>S4</b>	0.605	-0.1
<b>S5</b>	0.596	-0.5
<b>S6</b>	0.596	-0.5
<b>S7</b>	0.584	-1.1
<b>S8</b>	0.605	-0.1
<b>S9</b>	0.639	1.5
<b>S0</b>	0.559	-2.3
<b>Mean (S1-S9) (<math>\mu</math>)</b>	0.607	
<b>St. Dev. (S1-S9) (<math>\sigma</math>)</b>	0.021	

Table 24 shows the index values for corrosion mass loss. The highest (best) and lowest (worst) corrosion mass loss indices for overlay systems corresponded to S3 and S8, respectively. The highest and lowest indices for friction corresponded to S1 and S7, respectively (Table 24). Finally, the surface profile index was highest (best) for S7, and lowest (worst) for S4 (Table 25).

Table 24. Index values for corrosion mass loss.

<b>Corrosion Mass Loss Analysis</b>		
<b>Specimen</b>	<b>Aver. All. Groups % Change</b>	<b>Index</b>
<b>S1</b>	2.96	0.8
<b>S2</b>	3.06	0.6
<b>S3</b>	2.74	1.3
<b>S4</b>	3.70	-1.0
<b>S5</b>	3.74	-1.1
<b>S6</b>	3.56	-0.6
<b>S7</b>	2.99	0.7
<b>S8</b>	3.84	-1.3
<b>S9</b>	3.05	0.6
<b>S0</b>	2.87	1.0
<b>Mean (S1-S9) (<math>\mu</math>)</b>	<b>3.29</b>	
<b>St. Dev. (S1-S9) (<math>\sigma</math>)</b>	<b>0.41</b>	

Table 25. Index values for surface profile results.

<b>Surface profile</b>		
<b>Specimen</b>	<b>Avg. Rut Depth (in)</b>	<b>Index</b>
<b>S1</b>	0.050	0.2
<b>S2</b>	0.045	0.6
<b>S3</b>	0.039	0.9
<b>S4</b>	0.084	-1.8
<b>S5</b>	0.045	0.6
<b>S6</b>	0.050	0.2
<b>S7</b>	0.038	1.0
<b>S8</b>	0.079	-1.5
<b>S9</b>	0.058	-0.2
<b>S0</b>	0.015	2.3
<b>Mean (S1-S9) (<math>\mu</math>)</b>	0.054	
<b>St. Dev. (S1-S9) (<math>\sigma</math>)</b>	0.017	

In addition to calculating indices for individual parameters, three different combined indices were also calculated. Table 26 shows combined indices for all four measured parameters ( $I_4$ ). The individual indices were added together to arrive at the  $I_4$  values in Table 26. The highest and lowest  $I_4$  values correspond to S1 and S8, respectively. Figure 50 shows the  $I_4$  results in graphical form.

Table 26. Combined performance index  $I_4$  – Combined pull-out strength, friction, corrosion, and surface profile.

Combined Index $I_4$	
Specimen	Index
S1	3.2
S2	1.7
S3	1.8
S4	-2.5
S5	-0.5
S6	-0.8
S7	1.0
S8	-5.4
S9	1.5
S0 (Control)	1.1

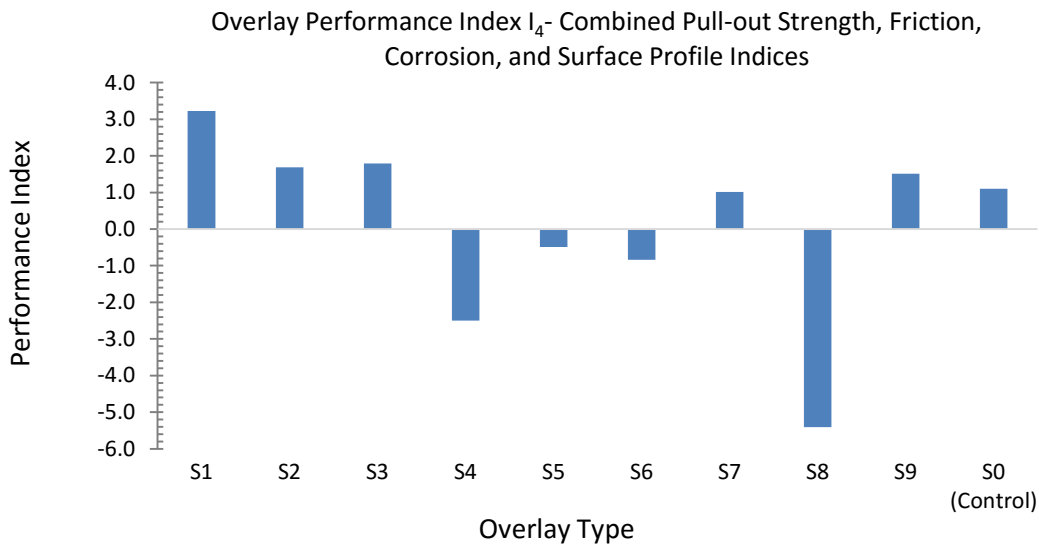

Figure 50. Overlay Performance Index ( $I_4$ ) - Combined pull-out strength, friction, corrosion, and surface profile indices.

Table 27 shows a combined index for three of the four parameters ( $I_3$ ). The indices associated with the pull-out strength, friction coefficient, and corrosion mass loss were added together to arrive at the  $I_3$  values in Table 26. This combined index is considered useful when surface rut is not a concern. The highest and lowest  $I_3$  values correspond to S1 and S8 (3.0 and -4.0), respectively. Figure 51 shows the results in graphical form.



Table 27. Combined performance index  $I_3$  – Combined pull-out strength, friction, and corrosion mass loss.

Combined Index $I_3$	
Specimen	Index
S1	3.0
S2	1.1
S3	0.9
S4	-0.7
S5	-1.0
S6	-1.1
S7	0.1
S8	-4.0
S9	1.7
S0 (Control)	-1.2

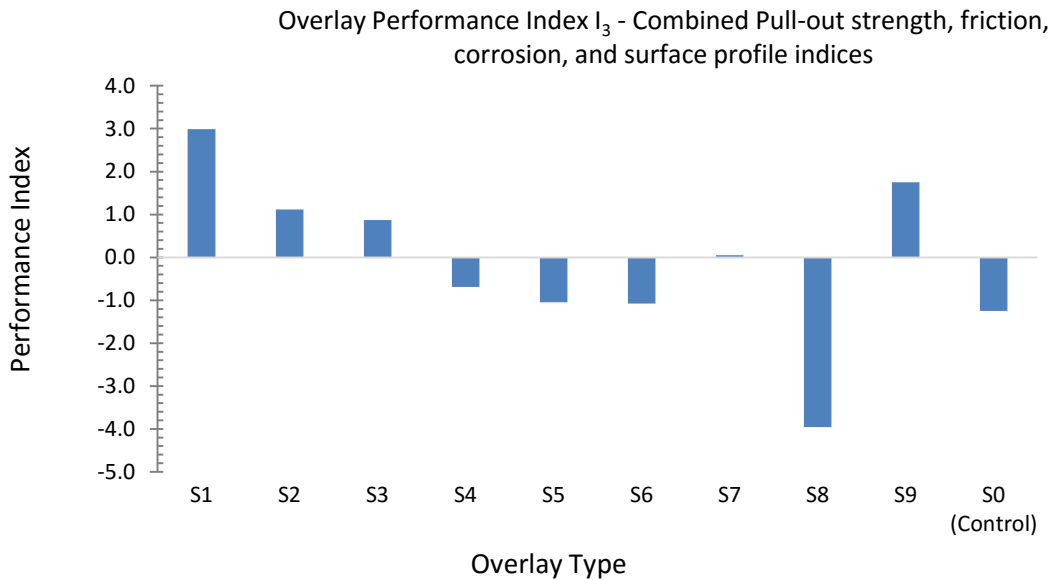

Figure 51. Overlay Performance Index ( $I_3$ ) - Including pull-out strength, friction, and corrosion indices.

Finally, Table 28 shows a combined index for two of the four parameters ( $I_2$ ). The indices associated with the pull-out strength and friction were added together to arrive at the  $I_2$  values in Table 28. This combined index is useful when corrosion and surface deformation are not considered important. Corrosion may not be an issue in some cases, such as overlay applications on unreinforced pavements. The highest and lowest  $I_2$  values correspond to S1 and S8 (2.2 and -2.6), respectively. Figure 52 shows the results in graphical form.

Table 28. Combined performance index  $I_2$  – Combined pull-out strength, and friction.

Combined Index $I_2$	
Specimen	Index
S1	2.2
S2	0.6
S3	-0.5
S4	0.3
S5	0.0
S6	-0.4
S7	-0.7
S8	-2.6
S9	1.2
S0 (Control)	-2.3

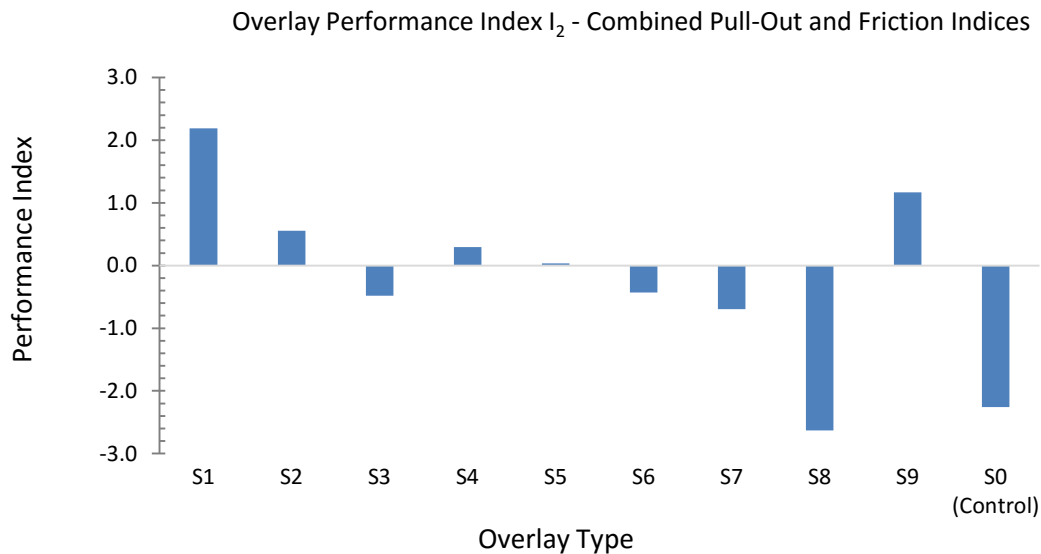

Figure 52. Overlay Performance Index ( $I_2$ ) - Including pull-out strength, and friction indices.

### 5.5.3 Observations on the Laboratory Test Results

Assuming that the overlay is installed properly on the concrete surface, and considering all of the results presented above, it is concluded that the epoxy-based overlay system with flint rock (S1) aggregate offers the best overall performance based on this laboratory test program. The system with an unacceptable performance was the polyester 2-lift system (S8). Complete delamination of the overlay occurred in laboratory tests of the S8 system.

Table 29 lists the two best (highest index) and the two worst (lowest index) results for all overlay types for the various performance parameters shown. Similarly, Table 30 shows the two best and the two worst cases in a color coded graphical form. The S1 overlay has the highest or the second highest index in all but one index or combined index category.

Table 29. Summary of best (highest) and worst (lowest) performance Indices.

Performance Parameter	Highest		2 <sup>nd</sup> Highest		Lowest		2 <sup>nd</sup> Lowest	
	Specimen	Value	Specimen	Value	Specimen	Value	Specimen	Value
Pull-out	S3	0.64	S1	0.54	S8	-2.54	S9	-0.38
Coefficient of Friction	S1	1.64	S9	1.55	S3	-1.12	S7	-1.06
Corrosion Mass Loss	S3	1.35	S1	0.80	S8	-1.32	S5	-1.08
Surface Profile	S7	0.97	S3	0.93	S4	-1.81	S8	-1.46
Combined Index I <sub>4</sub>	S1	3.23	S3	1.79	S8	-5.41	S4	-2.50
Combined Index I <sub>3</sub>	S1	2.99	S9	1.75	S8	-3.96	S6	-1.08
Combined Index I <sub>2</sub>	S1	2.19	S9	1.17	S8	-2.63	S7	-0.70

Table 30. Summary of best and worst indices in graphical form.

Overlay Type	Pull-out	Coefficient of Friction	Corrosion Mass Loss	Surface Profile	Combined Index I <sub>4</sub>	Combined Index I <sub>3</sub>	Combined Index I <sub>2</sub>
S1	Highest	Highest	Highest	2 <sup>nd</sup> Highest	Highest	Highest	Highest
S2	2 <sup>nd</sup> Highest	2 <sup>nd</sup> Highest	2 <sup>nd</sup> Highest	2 <sup>nd</sup> Highest	2 <sup>nd</sup> Highest	2 <sup>nd</sup> Highest	2 <sup>nd</sup> Highest
S3	Highest	Lowest	Highest	2 <sup>nd</sup> Highest	2 <sup>nd</sup> Highest	2 <sup>nd</sup> Highest	2 <sup>nd</sup> Highest
S4	2 <sup>nd</sup> Highest	2 <sup>nd</sup> Highest	2 <sup>nd</sup> Highest	Lowest	2 <sup>nd</sup> Lowest	2 <sup>nd</sup> Lowest	2 <sup>nd</sup> Lowest
S5	2 <sup>nd</sup> Highest	2 <sup>nd</sup> Highest	2 <sup>nd</sup> Lowest	2 <sup>nd</sup> Highest	2 <sup>nd</sup> Highest	2 <sup>nd</sup> Highest	2 <sup>nd</sup> Highest
S6	2 <sup>nd</sup> Highest	2 <sup>nd</sup> Highest	2 <sup>nd</sup> Highest	2 <sup>nd</sup> Highest	2 <sup>nd</sup> Highest	Lowest	2 <sup>nd</sup> Lowest
S7	2 <sup>nd</sup> Highest	2 <sup>nd</sup> Lowest	2 <sup>nd</sup> Highest	Highest	2 <sup>nd</sup> Highest	2 <sup>nd</sup> Highest	2 <sup>nd</sup> Lowest
S8	Lowest	2 <sup>nd</sup> Highest	Lowest	2 <sup>nd</sup> Lowest	Lowest	Lowest	Lowest
S9	2 <sup>nd</sup> Lowest	2 <sup>nd</sup> Highest	2 <sup>nd</sup> Highest	2 <sup>nd</sup> Highest	2 <sup>nd</sup> Highest	2 <sup>nd</sup> Highest	2 <sup>nd</sup> Highest

During freeze-thaw testing, it was observed that some aggregates would become loose and leave the overlay system after each round of freeze-thaw cycles. It is anticipated the loss of aggregates would continue with time. Since aggregates provide a physical barrier protecting the polymer against ultraviolet radiation from the sun, it is expected that a longer-term mode of damage may be related to UV degradation of the polymer following loss of aggregates.

## 5.6 Field Tests – Initial Friction Results

### 5.6.1 Initial BPT results

Table 31 show BPT friction values measured on the Marquette Interchange ramp before and after the application of overlays. Measurements were taken on the shoulder areas as well as the travel lanes. It should be noted that the BPT values are not the same as the friction values measured in the laboratory tests. Before overlay application, the shoulder areas had generally higher BPT values compared to the travel lanes.

### 5.6.2 Failure of an Overlay System

As reported by Ms. Julie Brooks of WisDOT, the polyester multi-lift system that was installed on the Marquette Interchange (Segment C) had delaminated at several areas after approximately two years of service. Figure 53 shows a piece of the delaminated overlay. The same type of system (but with a different type of aggregate) was tested in the laboratory (S8). The S8 specimens all had bond failure at the interface between the overlay and the concrete surface.

Table 31. Average Friction Test Results Using British Pendulum Tester (Marquette Interchange Ramp).

Ramp Segment	Before Overlay*		After Overlay**	
	Friction (travel Lane)	Friction (Shoulder)	Friction (travel Lane)	Friction (Shoulder)
A	74.7	75.5	65.5	69.6
B	63.2	77.8	76.1	75.1
C	67.0	80.4	85.9	91.9
D	67.2	78.9	79.9	82.0

\*Before overlay values are on concrete surface approx. 1 month before overlay placement (May 2013).

\*\*After overlay are on overlay surfaces but before opening ramp to traffic (June 2013).



Figure 53. Delaminated multi-lift polyester overlay (from the Marquette Interchange ramp).

## 6.0 CONCLUSIONS AND RECOMMENDATIONS

### 6.1 Summary and Conclusions

Deterioration of concrete bridge decks is a major maintenance concern particularly in the northern snow-belt regions where deicing salt is used to maintain traffic during winter months. Overlays and sealers have long been utilized in protection and repair strategies for bridge decks. Polymer overlays are used on decks to reduce the penetration of chloride ions (and the resulting corrosion) and to improve skid resistance (increase friction). Because of their small thicknesses (generally 0.25 to 0.75 in), polymer overlays impose less additional dead weight and can be applied more rapidly compared to other types of overlay.

States may utilize differing criteria when deciding whether to use overlays. These criteria may include chloride content at the level of reinforcing bars, percent delamination of the deck, and the depth of cover over reinforcement. For example, a study in Virginia (Sprinkel et al., 1993) recommended that all concrete with chloride contents over 1.0 lb./yd<sup>3</sup> be removed prior to placement of overlay. The rationale for such a recommendation is that the corrosion activity may continue unabated when significant chloride contamination exists under the overlay.

The objectives of this research project were to explore the effectiveness and durability of thin polymer overlays with respect to restoring and protecting bridge decks, improving safety, and extending service life; to assess and compare performance of selected thin polymer overlay systems under laboratory test conditions; and to suggest appropriate bridge deck maintenance strategies related to this research.

An experimental research program was designed and conducted to study and compare the performance of nine different overlay systems (designated S1 through S9) against each other and against a set of uncoated control specimens (designated S0). A total of 84 reinforced concrete specimens were subjected to accelerated corrosion (saltwater exposure and imposition of an electrical potential to the reinforcing bars), freeze-thaw cycles, heat/ultraviolet/rain exposure cycles, and tire wear tests (including simulated “snow plow” passages). Application of overlays on previously chloride-contaminated concrete was also studied through exposure of two sets of specimens to increasing chloride (corrosion) levels prior to application of overlays. A number of parameters including pull-out strength, friction, deformation due to tire passages (rutting), and corrosion mass loss were measured. The specimens were dissected at the conclusion of testing for further examination and measurement of corrosion mass loss on the top reinforcing bars.

The results of the testing program are discussed in detail in this report. Table 32 shows a graphical summary of finding (rankings) from various specimen groups.

Table 32. Summary of Experimental Results (Rankings).

Specimen ranking	Pull-out	Coefficient of Friction	Corrosion Mass Loss	Surface Profile	Combined Index I <sub>4</sub>	Combined Index I <sub>3</sub>	Combined Index I <sub>2</sub>
S1	2nd	1st	2nd	5th	1st	1st	1st
S2	4th	3rd	5th	3rd	3rd	3rd	3rd
S3	1st	9th	1st	2nd	2nd	4th	7th
S4	5th	4th	7th	9th	8th	6th	4th
S5	3rd	6th	8th	4th	6th	7th	5th
S6	7th	7th	6th	6th	7th	8th	6th
S7	6th	8th	3rd	1st	5th	5th	8th
S8	9th	5th	9th	8th	9th	9th	9th
S9	8th	2nd	4th	7th	4th	2nd	2nd

The main results can be summarized as follows:

- One of the nine overlay systems tested (S8 - a 2-lift polyester multi-lift overlay) exhibited complete delamination from the concrete surface during testing even though its initial pull-out strength was in line with the other eight overlay types. This overlay system had the worst overall performance based on numerical indices given to various performance parameters, or combinations of those parameters. In general, aside from the poor performance of S8, there were variations in performance of all other TPO systems tested (as discussed below); however, such differences were not drastic.
- Friction test results prior to environmental exposures indicated that the tined concrete surface (concrete surface without overlay - control) had the highest initial friction values. However, the control specimen (without overlay) had the lowest friction values at the end of all testing. This indicates that the polymer overlay systems help retain surface friction values.
- The overlay system utilizing epoxy resin with flint rock provided the highest friction, and the best overall performance indices, at the end of testing.
- Of the three aggregate types (flint, granite, and calcined bauxite) used with the same epoxy resin (S1, S2, S3), the flint rock resulted in the highest friction values at the end of tests, while calcined bauxite exhibited the lowest friction results. The only overlay system with the taconite aggregate (S9) provided the second highest friction values at the end of testing.
- The epoxy-based overlays (with different aggregate types) and the polyester premix system offered reduced corrosion losses when compared to the control specimens. However, the addition of

overlays does not significantly reduce corrosion mass loss when specimens are already contaminated with chlorides prior to installation of overlays.

- As far as pull-out strength (at the end of testing) is concerned, the epoxy overlay systems with calcined bauxite and flint aggregates (S3 and S1) provided the highest and second highest strengths, respectively. The lowest and the second lowest pull-out strengths were observed in the polyester multi-lift system (S8) and the overlay system with taconite (S9), respectively.
- The main advantage of thin polymer overlays is the long-term preservation of friction coefficients as the deck ages relative to the concrete without overlay. Therefore, for applications where friction enhancements are needed, the thin polymer overlays are recommended unless chloride contamination, corrosion, and/or deck surface conditions preclude its use.
- Proper installation of the overlays is crucial. Special effort and proper quality controls are needed to ensure that the overlay is installed properly. If the installation is done correctly, most of the tested systems (with the exception of the system described above) can perform without premature delamination.
- During freeze-thaw testing, it was observed that some aggregates would become loose and leave the overlay system after each round of freeze-thaw cycles. It is anticipated that the loss of aggregates would continue with time. Since aggregates provide a physical barrier protecting the polymer against deterioration due to ultraviolet radiation from the sun, it is expected that a longer-term mode of damage may be related to UV degradation of the polymer following loss of aggregates.
- Based on information in the literature, survey findings, and results from this study, it is anticipated that the service life of a 2-lift thin polymer overlay would be on the order of 7 to 15 years, if early premature failures do not occur. A service life of 10 years can be assumed for economic analyses.
- If the purpose for the installation of the thin polymer overlay is to protect an uncontaminated deck against corrosion, a more cost effective approach may be to apply a penetrating sealer shortly after construction, and repeating the sealer application periodically thereafter. However, on heavily-travelled roads, routine reapplication of sealers may be disruptive to traffic. In such cases, thin polymer overlays may be applied as a corrosion protection measure, especially if the overlay is applied early in the bridge deck's life before substantial chloride contamination has occurred.
- The addition of polymer overlays does not significantly reduce corrosion mass loss in bridge decks with high levels of prior chloride contamination. Therefore, the placement of a thin polymer

overlay on a chloride contaminated bridge deck undergoing active corrosion of the embedded steel cannot be considered to be an effective corrosion mitigation strategy. Such a step (application of thin polymer overlay) may still be taken in these situations for other reasons such as improving friction or providing a smooth riding surface over a limited time period. However, the overlay must be installed on sound concrete under all circumstances, and it must be realized that the overlay may eventually fail due to effect of corrosion of the underlying reinforcement, if not for other factors.

## **6.2 Recommended Guidelines**

A proper strategy for maintenance of bridge deck involves consideration of the effectiveness of relevant technologies/products and their associated costs. There are three basic preventive or restorative strategies/approaches for bridge deck maintenance that are considered in these guidelines. These include: 1) periodic application of penetrating sealers; 2) application of thin polymer overlays; and 3) installation of concrete overlays. The objective for the periodic application of sealers would be to protect the deck against corrosion due to deicing salts. The objectives for the use of thin polymer overlays could be corrosion protection, enhancement/restoration of surface friction (skid resistance), and/or restoration of surface profile. The objectives for installation of a concrete overlay could be corrosion protection and/or restoration of surface profile.

The material costs for thin polymer overlays (on a per square foot basis) are at least an order of magnitude higher than the corresponding material costs for silane or siloxane-based penetrating sealers (Morse, 2009). On the other hand, installation costs for thin polymers are similarly higher as well. Surface preparations for thin polymer overlay applications involve more stringent requirements including shot blasting, and such systems are potentially susceptible to premature failure (debonding) due to improper surface preparations, insufficient mixing, moisture conditions, environmental factors, etc. An informal survey of recent (2016) costs from suppliers and the Wisconsin Department of Transportation indicates that the average costs (material and installation) of penetrating sealers and 2-lift thin polymer overlays are on the order of \$0.31 and \$4.60 per square foot of deck area, respectively. The cost of premix overlay systems is higher. The cost for the concrete overlay would be the highest of all overlay options (Morse, 2009).

Based on the review of literature, survey results, previous WHRP research (Pritzl et al. 2014a, b; 2015) and the findings from this study, the following guidelines are recommended for maintenance of bridge decks in Wisconsin:



- 1) All new bridge decks should receive their first application of penetrating sealers shortly after construction to maximize the corrosion protection benefits. The application of penetrating sealers should be repeated at preferably 3 to 5 year intervals for the entire service life of the bridge deck (Morse, 2009 and Sudbrink, 2013). Bridges with higher average daily traffic (ADT of 7500 or higher) should be treated on a 3-yr cycle (or better) to address higher surface wear due to traffic. Sealers on bridge decks with ADT of less than 2500 should be reapplied at 5 year intervals (or better). All other bridge decks should receive a sealer reapplication every 4 years (or better).
- 2) Applications of penetrating sealers should ideally be performed in late spring and summer so that spring rains could wash the near-surface chlorides that are accumulated during the winter.
- 3) If the first application of penetrating sealer is not possible immediately after construction, such applications should be implemented while the deck rating has not dropped below 9, or within the first 5 years of service life. Initial application of penetrating sealers when the deck rating is 8 may still provide some benefits, even though its effectiveness would be reduced substantially because of accumulation of chlorides in the concrete.
- 4) When the ADT is high, and the cost (including traffic disruptions) associated with maintenance of traffic during frequent sealer applications are considered unacceptable, the application of thin polymer overlays may be considered as an acceptable corrosion protection strategy. Such an application should ideally occur shortly after construction of the bridge deck (or less desirably within the first 5 years of service) to maximize the corrosion protection benefits.
- 5) All sealer and thin polymer overlay applications should be performed after existing deck cracks have been properly sealed with crack sealers that are compatible with the deck sealer or the overlay. It should be noted that any deck cracking occurring after placement of 2-lift overlays may be reflected through the overlay.
- 6) When the bridge deck rating reaches 7 and no previous protection measures had been taken, applications of penetrating sealer or thin polymer overlay may potentially not be beneficial and they are not recommended.
- 7) When the deck rating reaches 6, the recommended approach would be to install a latex- or microsilica-modified concrete overlay. This approach has been used in Minnesota, and bridge deck service life has likely been enhanced because of this strategy (Tabatabai et al., 2016). Although this approach is costlier, applications of sealers or thin polymer overlays at such advanced stage of deterioration would likely not be beneficial from a corrosion protection standpoint.
- 8) When the bridge deck rating reaches 5 or lower, the entire bridge deck should be replaced.

- 9) The application of thin polymer overlays when the deck rating is 8 or 7 can be considered if an important objective is to achieve higher surface friction (better skid resistance) or to restore the deck surface profile (riding quality). However, such considerations should carefully compare and evaluate the expected service life of the overlay (which would likely be reduced due to the condition of the deck) against the remaining service life of the deck itself.
- 10) Any applications of thin polymer overlays must be on solid concrete surfaces that have been properly repaired. Any cementitious patch repairs must be at least 28 days old to preclude failure of the overlay due to vapor pressure from the patch.

## 7.0 REFERENCES

- 1) ACI 503, “Use of Epoxy Compounds with Concrete,” ACI 503-R93, American Concrete Institute, Detroit, MI, 1993.
- 2) Barnhart, J.E., “Thin Bonded Overlay and Surface Laminates,” Report No. FHWA/HWY-2001/07, Ohio Department of Transportation, 2001, 35 p.
- 3) Erukulla, S., “Refining a Laboratory Procedure to Characterize Change in Hot-Mix Asphalt Surface Friction,” Master’s thesis, Auburn University, May 2011.
- 4) Evans, J.F., “Evaluation of the SafeLane overlay system for crash reduction on bridge deck surfaces,” Report No. MN/RC 2010-13, Minnesota Department of Transportation, <http://ntl.bts.gov/lib/32000/32800/32895/201013>, 2010, 33 pp.
- 5) Germann Instruments, NDT Systems, 2010, 112–115.
- 6) Krauss, P.D., Lawler, J.S., and Steiner, K.A., “Guidelines for Selection of Bridge Deck Overlays, Sealers and Treatments,” Report to the National Cooperative Highway Research Program, May 2009.
- 7) Morse, K.L., “Effectiveness of Concrete Deck Sealers and Laminates for Chloride Protection of New and In Situ Reinforced Bridge Decks in Illinois,” Report No. FHWA/IL/PRR-155, Illinois Department of Transportation, October 2009, 57 pp.
- 8) Nelsen, T., “Performance of Concrete Bridge Deck Surface Treatments,” Master of Science thesis, Department of Civil and Environmental Engineering, Brigham Young University, Utah, August 2005.
- 9) Pritzl, M.D, Tabatabai, H., and Ghorbanpoor, A., “Long-term chloride profiles in bridge decks treated with penetrating sealer or corrosion inhibitors,” *Construction and Building Materials*, 101(2015):1037-1046, November 2015.
- 10) Pritzl, M.D., Tabatabai, H., and Ghorbanpoor, A., “Laboratory Evaluation of Select Methods of Corrosion Prevention in Reinforced Concrete Bridges,” *International Journal of Concrete Structures and Materials*, Springer, Vol. 8, No. 3, September 2014, pp. 201-212 (open access).
- 11) Pritzl, M.D., Tabatabai, H., and Ghorbanpoor, A., “Laboratory Assessment of Select Methods of Corrosion Control and Repair in Reinforced Concrete Bridges,” *International Journal of Corrosion*, Volume 2014 (2014), Article ID 175094, 11 pages.

- 12) Pfeifer, B.A., and Kowlaski, G., "Evaluation of Thin Lift Polymer Bridge Deck Overlays on I-57 Bridges at Clifton, IL," Report No. IL-PRR-132, Illinois Department of Transportation, June 1999, 29 pp.
- 13) Rogers, C.E., Bouvy, A., and Schiefer, P., "Thin Epoxy Overlay/Healer Sealer Treatments on Bridge Decks," Report by Bridge Field Services, Michigan Department of Transportation, available at [https://www.michigan.gov/documents/mdot/MDOT\\_Research\\_Report\\_RC1422\\_200642\\_7.pdf](https://www.michigan.gov/documents/mdot/MDOT_Research_Report_RC1422_200642_7.pdf), November 2011.
- 14) Soltesz, S., "Evaluation of Thin Overlays for Bridge Decks," Report FHWA-OR-RD-11-05, Oregon Department of Transportation, November 2010, 78 pp.
- 15) Sprinkel, M.M., "Evaluation of Latex-Modified and Silica Fume Concrete Overlays Placed on Six Bridges in Virginia," Report VTRC 01-R3, Virginia Transportation Research Council, August 2000.
- 16) Sprinkel, M.M., Roosevelt, D.S., Flintsch, G.W., Izeppi, D., and Mokarem, D.W., "Evaluation of the Cargill SafeLane surface overlay," Report No. VTRC 09-R82009, Virginia Transportation Research Council, [http://www.virginiadot.org/vtrc/main/online\\_reports/pdf/09-r8.pdf](http://www.virginiadot.org/vtrc/main/online_reports/pdf/09-r8.pdf), 2009, 52 pp.
- 17) Sprinkel, M.M., Sellars, A.R., and Weyers, R.E., "Rapid Concrete Bridge Deck Protection, Repair, and Rehabilitation," SHRP-S-344, Strategic Highway Research Program, National Research Council, 1993.
- 18) Sudbrink, B., "Investigation of Silane Treatment in Concrete Using Various Non-Destructive Techniques," Masters Thesis, Oklahoma State University, Stillwater, OK, 2013.
- 19) Tabatabai, H., Ghorbanpoor, A., and Pritzl, M.D., "Evaluation of Select Methods of Corrosion Prevention, Corrosion Control, and Repair in Reinforced Concrete Bridges," SPR #0092-0606, Wisconsin Highway Research Program (WHRP 09-04), October, 2009, 343 pp.
- 20) Tabatabai, H., Ghorbanpoor, A., and Turnquist-Nass, A., "Rehabilitation Techniques for Concrete Bridges," WHRP 05-01, 2005.
- 21) Tabatabai, H., Lee, C.-W., and Tabatabai, M. A., "Survival Analyses for Bridge Decks in Northern United States," 2016.
- 22) Weyers, R.E., Fitch, M.G., Larsen, E.P., Al-Qadi, I.L., Chamberlin, W.P., and Hoffman, P.C., "Service Life Estimates," SHRP-S-668, Strategic Highway Research Program, National Research Council, 1994.

23) Wilson, D.L., and Henley, E.H., “Thin Polymer Bridge Deck Overlays: WSDOT’s Ten Year Evaluation,” Report No. WA-RD 374.1, Washington State Department of Transportation, February 1995, 100 p.